



TEC Thermal Printer

# **B-370 SERIES**

## **Maintenance Manual**

Document No. **EM18-33012**

Original **Jun., 1994**

(Revision )

**WARNING!**

*Follow all manual instructions. Failure to do so could create safety hazards such as fire or electrocution.*

- NOTES:**
- 1. Manual instructions must be followed when installing option kits or adding cables to avoid system failures and to insure proper performance and operation.*
  - 2. Failure to follow manual instructions or any unauthorized modification, substitution or change to this product will void the limited product warranty.*

## TABLE OF CONTENTS

	Page
1. UNPACKING .....	1- 1
1.1 Procedures .....	1- 1
1.2 Checks .....	1- 1
2. MAJOR UNIT REPLACEMENT .....	2- 1
2.1 REPLACING THE PS UNIT, I/F PC BOARD AND CPU PC BOARD .....	2- 2
2.2 REPLACING THE STEPPING MOTOR .....	2- 4
2.3 REPLACING THE RIBBON MOTORS .....	2- 5
2.4 REPLACING THE TAKE-UP MOTOR .....	2- 5
2.5 REPLACING THE SOLENOID .....	2- 7
2.6 REPLACING THE PRINT HEAD .....	2- 8
2.7 REPLACING THE PLATEN AND FEED ROLLER .....	2- 9
2.8 REPLACING THE PAPER SENSOR .....	2-10
2.9 REPLACING THE RIBBON BACK TENSION BLOCK .....	2-11
2.10 REPLACING THE PINCH ROLLER SHAFT ASS'Y .....	2-11
2.11 CORRECTING SKEW PRINTING .....	2-14
3. INSTALLATION PROCEDURE FOR THE OPTIONAL EQUIPMENT .....	3- 1
3.1 HIGH SPEED PC INTERFACE BOARD (B-4800-PC-QM) .....	3- 1
3.2 CUTTER MODULE (B-4203-QM) .....	3- 3
3.3 MEMORY MODULE .....	3- 6
3.4 FANFOLD PAPER GUIDE MODULE (B-4903-FF-QM) .....	3- 7
4. MECHANISM DESCRIPTIONS .....	4- 1
4.1 CUTTER DRIVE (CUT MODE) .....	4- 1
4.2 HARNESS WIRING .....	4- 2
5. TROUBLESHOOTING .....	5- 1
6. DIAG. TEST OPERATION .....	6- 1
7. PROGRAM DOWN LOAD .....	7- 1
7.1 FLOPPY DISK .....	7- 1
7.2 SETUP .....	7- 1
7.3 DOWN LOAD PROCEDURE .....	7- 2
7.4 ERROR CODE .....	7- 3

### **CAUTION:**

- 1. This manual may not be copied in whole or in part without prior written permission of TOSHIBA TEC.*
- 2. The contents of this manual may be changed without notification.*
- 3. Please refer to your local Authorized Service representative with regard to any queries you may have in this manual.*

# 1. UNPACKING

## 1.1 PROCEDURE

- 1) Open the carton.
- 2) Unpack the accessories from the carton.
- 3) Unpack the side pad (L)/(R) and the printer from the carton.
- 4) Place the printer on a level surface.

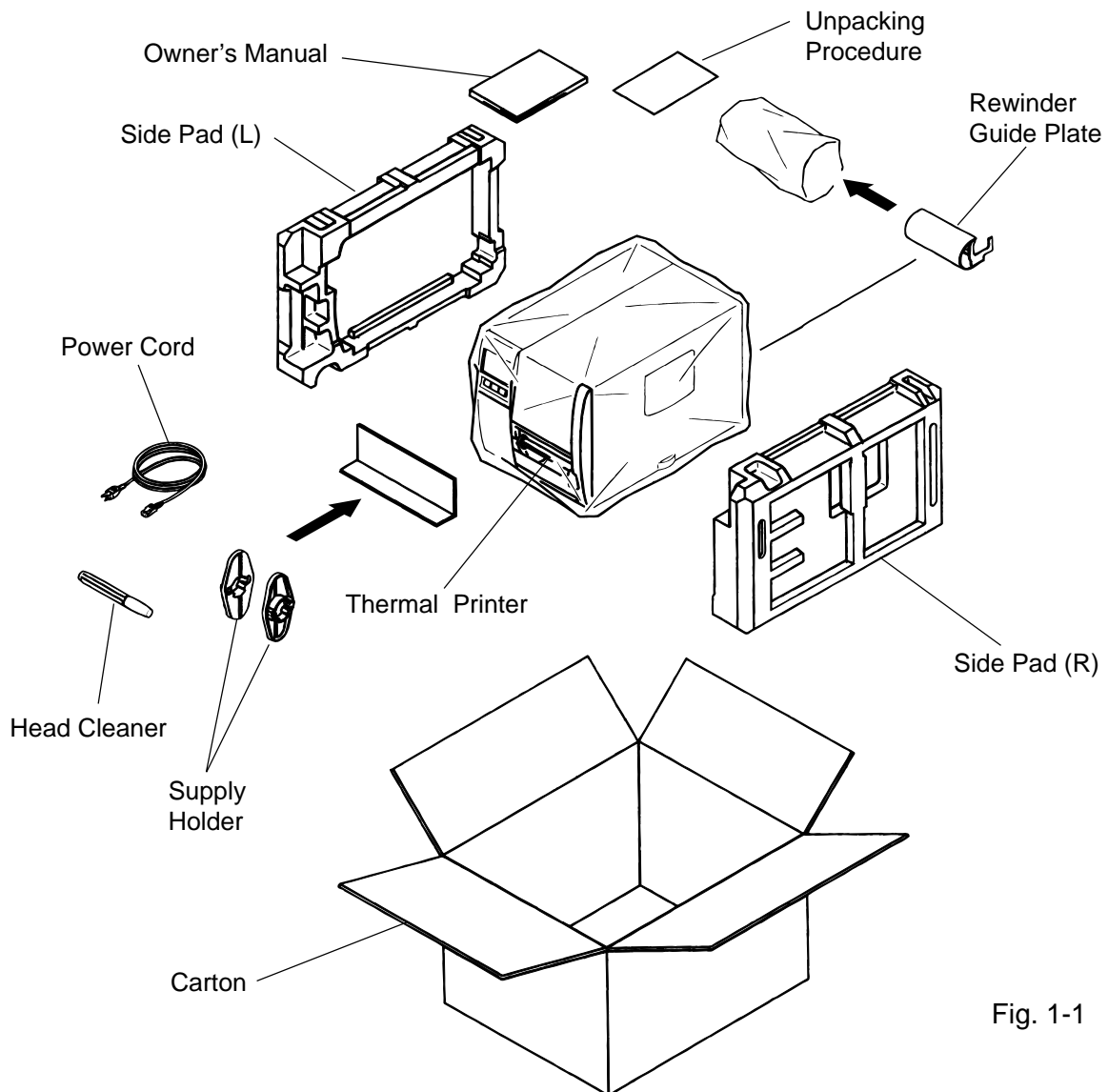

Fig. 1-1

## 1.2 CHECKS

- 1) Check for any damage or scratches on the machine.
- 2) Confirm that none of the accessories are missing.

**NOTE:** Keep the carton and side pads for later transport.

## 2. MAJOR UNIT REPLACEMENT

### WARNING!

Disconnect power cord before replacing important parts.

### CAUTION:

1. NEVER separate the ribbon motors from the attaching plate (bracket), because doing so will change their adjustment. (See Fig. 2-8)
2. NEVER remove the two screws painted red on the side of the print block. (See Fig. 2-13)
3. NEVER remove the four screws on the side of the print block. (See Fig. 2-13)
4. NEVER remove the four screws painted red fixing the right plate and reinforcing plate. (See Fig. 2-15) However, the machine with a serial number of 4T x x x x x or later is not equipped with the red screws because of the change in the right plate shape.
5. NEVER remove unmentioned screws because doing so will change their adjustment.

- 1) Turn the power off.
- 2) Open the top cover to remove the four FL-3x5 screws. Slide the top cover to the left to release the damper and remove the top cover.
- 3) Remove the seven screws (FL-4x5 and B-4x5) to remove the left side cover.
- 4) Disconnect the FAN motor connector from the PS unit.

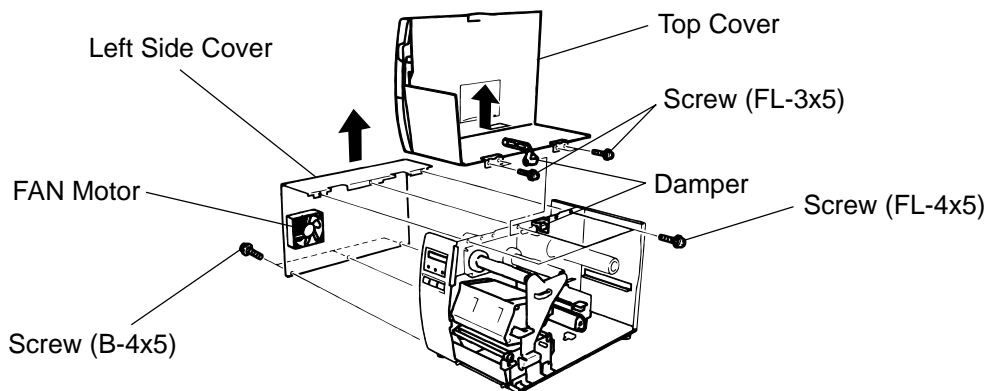

Fig. 2-1

**NOTE:** Instructions to remove the top cover and left side cover are omitted from each removal/installation procedure provided below.

### ■ Lubrication

**CAUTION:** 1) Lubrication: During parts replacement  
2) Kinds of oil: FLOIL G-488: 1 Kg can. (Part No. 19454906001).

Any machine is generally in its best condition when delivered; therefore, it is necessary to try to keep this condition. Unexpected failure occurs due to lack of oil, debris or dust. To keep its best condition, periodically clean the machine and apply proper kinds of oil to each part in which lubrication is needed.

Although the frequency of lubrication varies according to how much the machine is used, at least it is necessary to lubricate before the machine becomes dry. It is also necessary to wipe off excessive oil as it collects dirt.

**CAUTION:** Do not spray the inside of the printer with lubricants. Unsuitable oil can damage the mechanism.

## 2.1 REPLACING THE PS UNIT, I/F PC BOARD AND CPU PC BOARD

**CAUTION:**

*Replace only with same type and ratings of fuse for continued protection against risk of fire.*

- 1) Remove the three FL-4x6 screws and disconnect the two connectors to detach the PS unit.
- 2) Remove the FL-3x5 screw and the four locking supports to remove the I/F PC board.

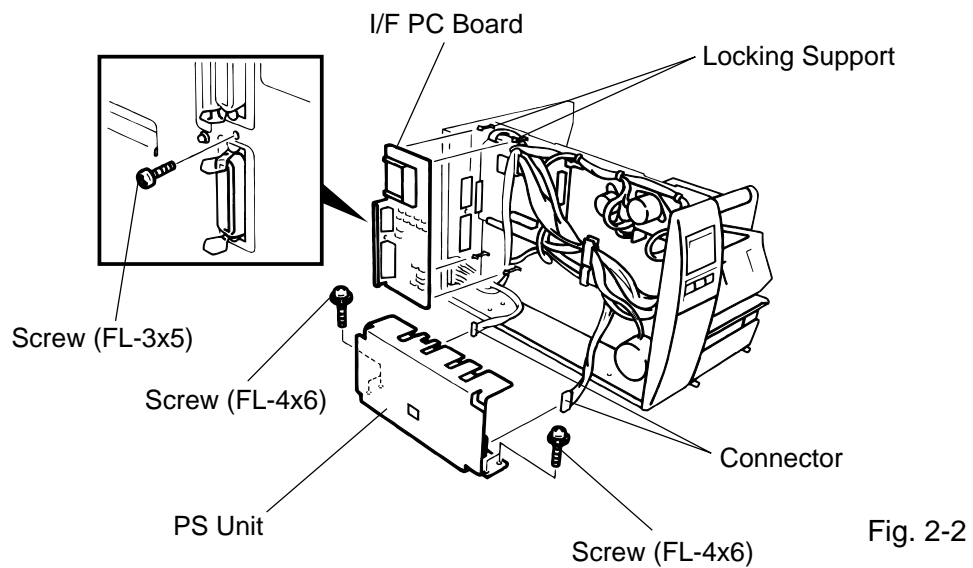

- 3) Disconnect the 13 connectors from the CPU PC board.
- 4) Remove the six screws (SM-3x6B, SM-3x6C) to detach the CPU PC board from the printer.

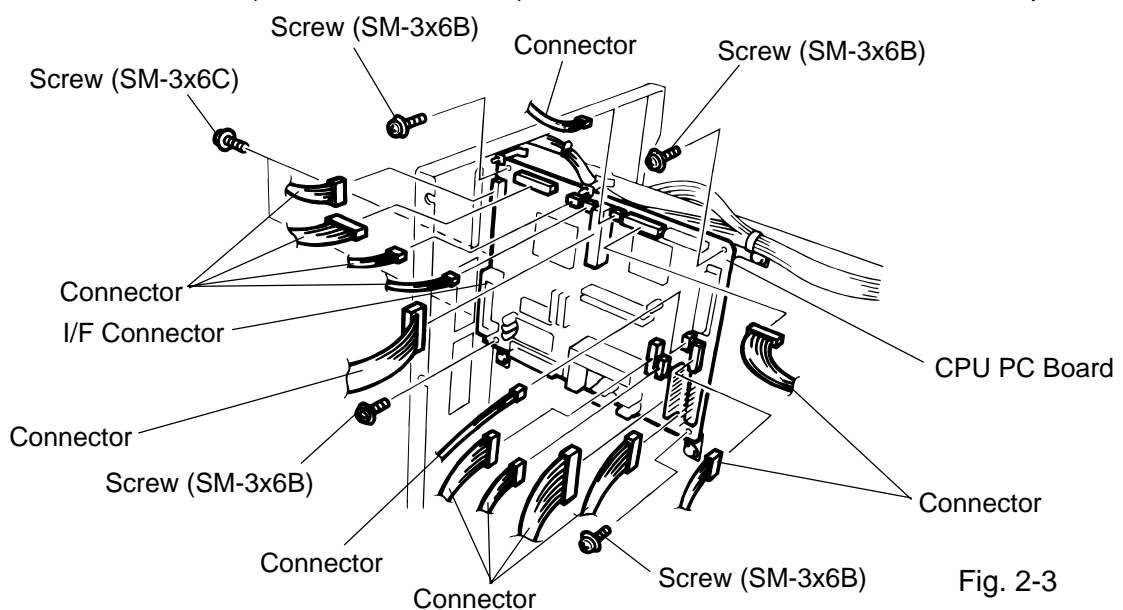

- 5) Replace the PS unit, I/F PC board and CPU PC board. Insert the connectors correctly and install in the reverse order of removal above. Do not mount the left side cover and top cover.

- 6) Adjust the ribbon end sensor.  
Use the following Ribbons; TTM-78 (Maker: Fujicopian)

- ① Set the ribbon so that the ribbon end sensor can detect the ribbon. Turn the power on.
- ② Turn the VR2 so that the voltage between Pin 1 (GND) and Pin 7 of CN10 is  $3.0 \pm 0.2$  V with an oscilloscope.
- ③ Turn the power off and mount the left side cover and top cover.

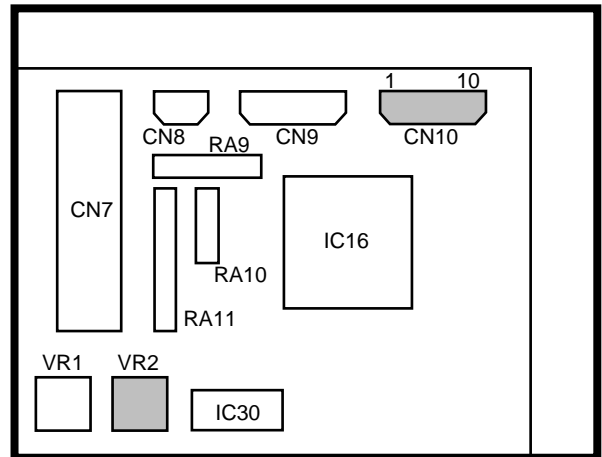

Fig. 2-4

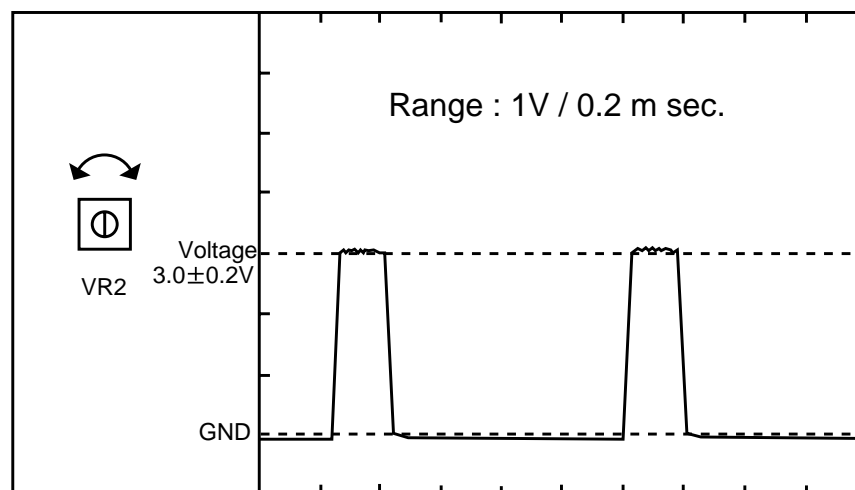

Fig. 2-5

- 7) Adjust the black mark sensor.  
As the black mark sensor is adjusted by key entries in system mode, refer to page 6-39 for the adjustment procedure.
- 8) Adjust the feed gap sensor.  
As the feed gap sensor is adjusted by key entries in system mode, refer to page 6-40 for the adjustment procedure.

**CAUTION:**

Be careful when replacing the CPU PC board, since a non-resettable counter (IC12) is installed on this board. (Refer to Section 6.2.1 Maintenance Counter Printing.)

If this counter should be reset, replace IC12.

## 2.2 REPLACING THE STEPPING MOTOR

- 1) Remove the two black screws to detach the front plate, remove the two FL-4x6 screws to detach the belt cover.

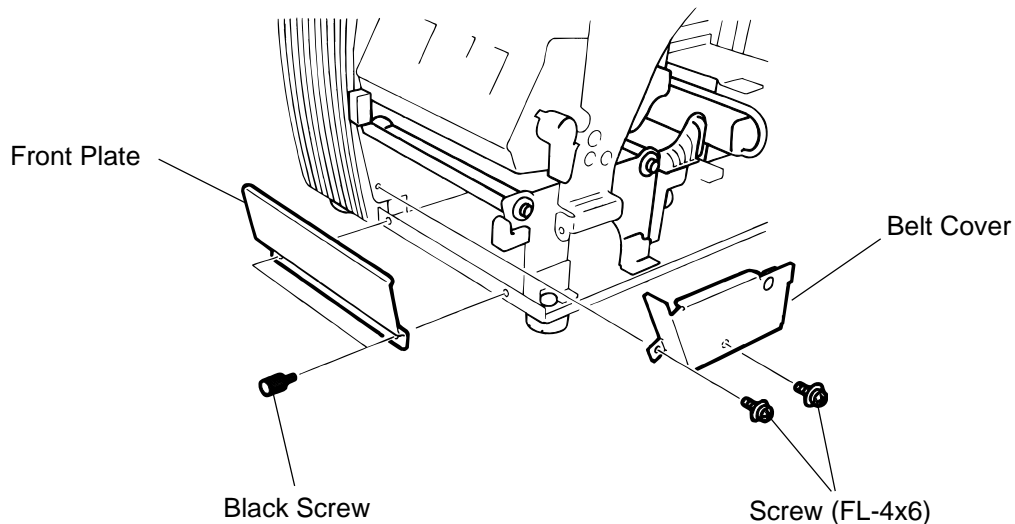

Fig. 2-6

- 2) Unclamp and disconnect the connector from CN14 on the CPU PC board.
- 3) Remove the two SM-4x8B screws, loosen the two belts from the pinion gear, and remove the stepping motor.

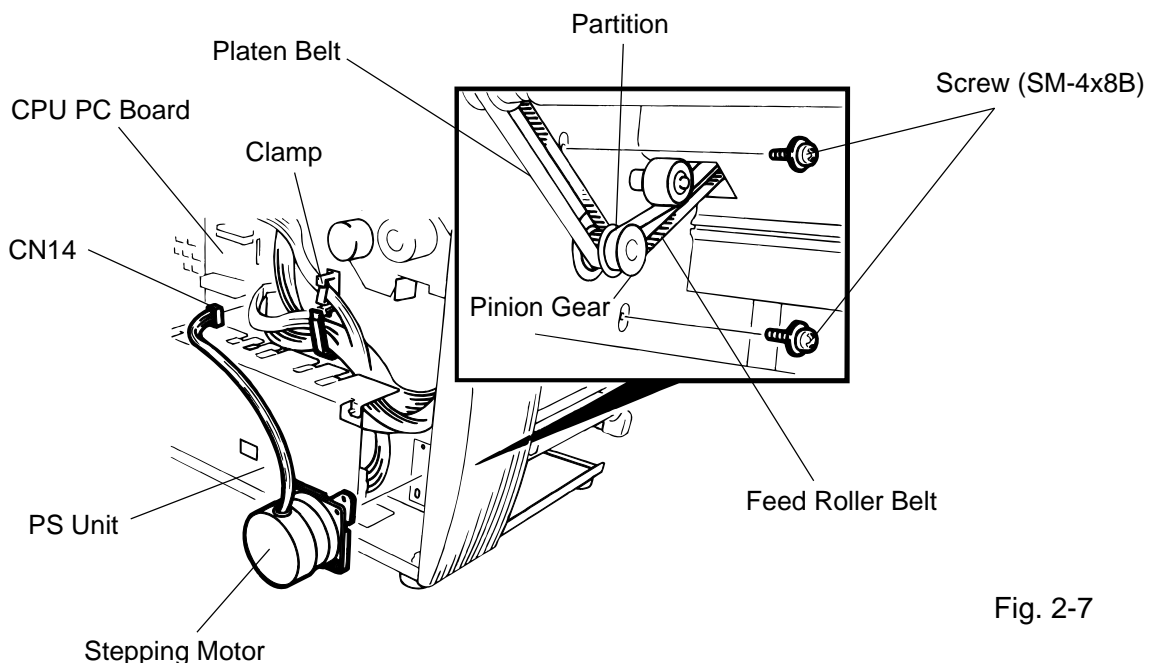

Fig. 2-7

- 4) When replacing the stepping motor, place the platen belt first then the feed roller belt around the pinion gear so that the partition is positioned between two belts. Hold down the stepping motor at  $3.5 \text{ kg} \pm 300 \text{ g}$  force and secure it so that the belts have no slack or disengagement.
- 5) Reassemble in the reverse order of removal.



## 2.3 REPLACING THE RIBBON MOTORS

**CAUTION:**

*NEVER separate the ribbon motors from the attaching plate because doing so will change their adjustment.*

- 1) Disconnect the connector and remove the two SM-3x5B screws to detach the ribbon motors.

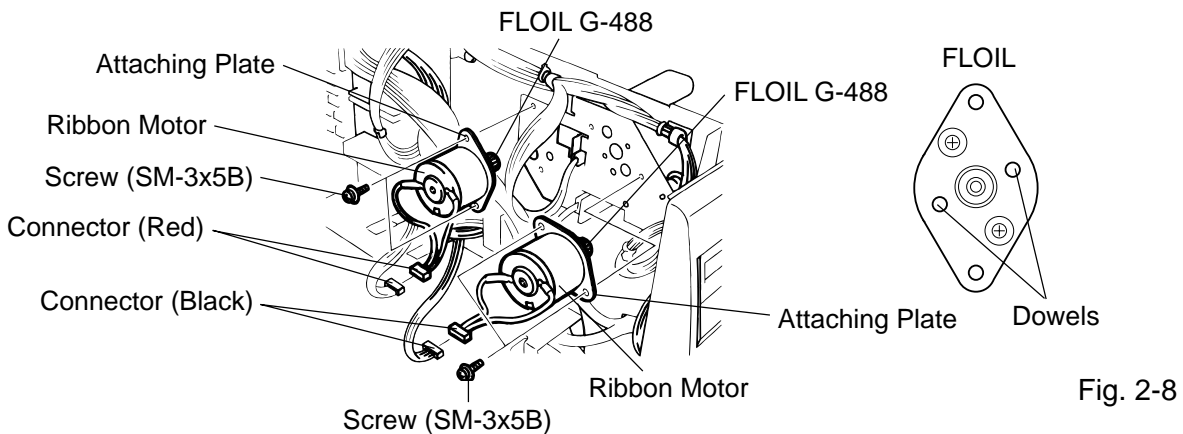

- 2) Replace the ribbon motors, then align the dowels to attach the ribbon motors. Reassemble in the reverse order of removal.

## 2.4 REPLACING THE TAKE-UP MOTOR

**CAUTION:**

*NEVER separate the take-up motor from the bracket because doing so will change the adjustment.*

**NOTE:** The following procedure can be employed without removing the top cover and left side cover.

- 1) Remove the four FL-3x5 screws to detach the motor cover.
- 2) Remove the connector for the rewind full sensor (LED).
- 3) Disconnect the connector from the CN1 on the PWM PC board and remove the two FL-3x5 screws to detach the take-up motor.

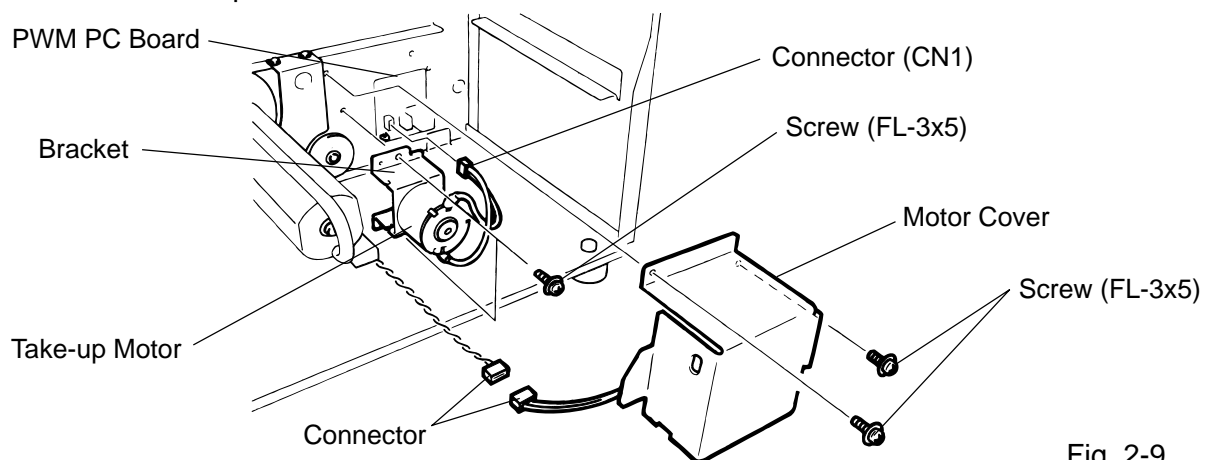

- 4) Replace the take-up motor, then align the dowels to attach the motor cover and rewind full sensor (Tr).

## 2.5 REPLACING THE SOLENOID

**NOTE:** The following procedure can be employed without removing the top cover and left side cover.

- 1) Before removing the ribbon stopper, check its attaching direction for later installation. Remove the ribbon stopper from the ribbon shaft on which the ribbon is wound.
- 2) Remove the two SM-4x8B screws, disconnect the connector CN1 on the RSV PC board to detach the solenoid unit.

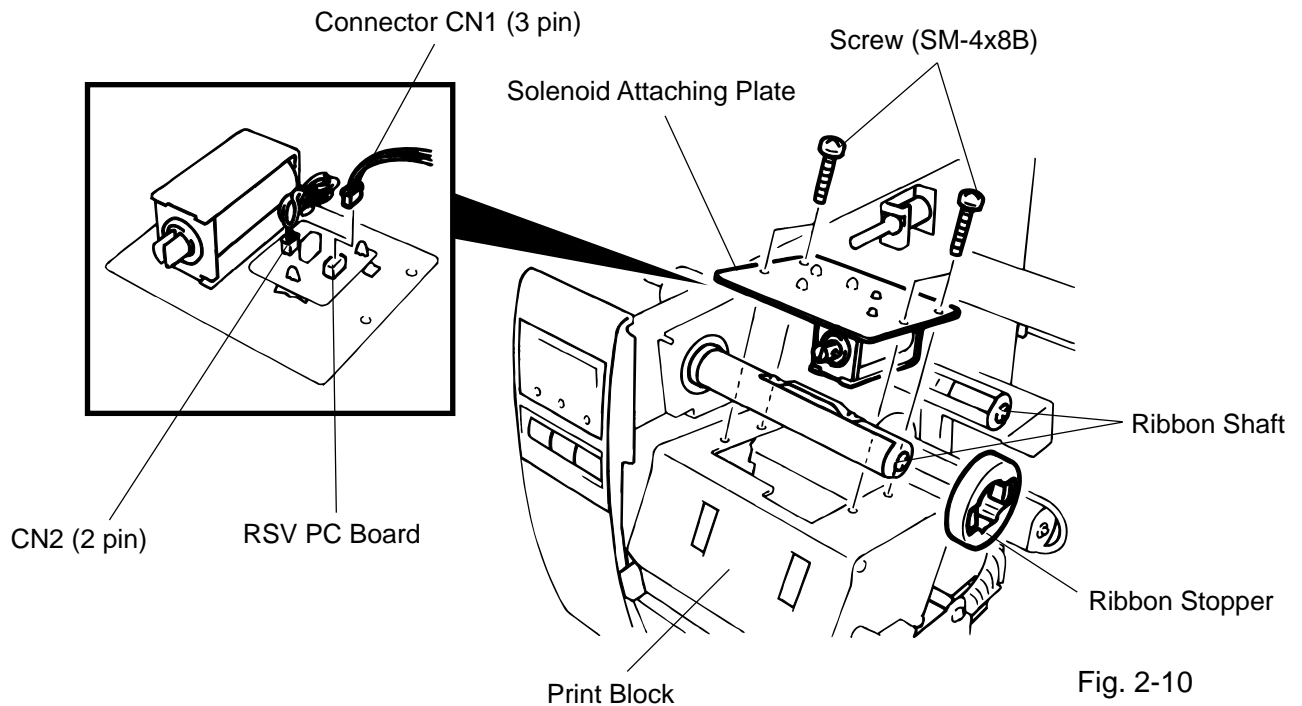

Fig. 2-10

- 3) Remove the two SM-3x5B screws and disconnect the CN2 connector on the RSV PC board to detach the solenoid.

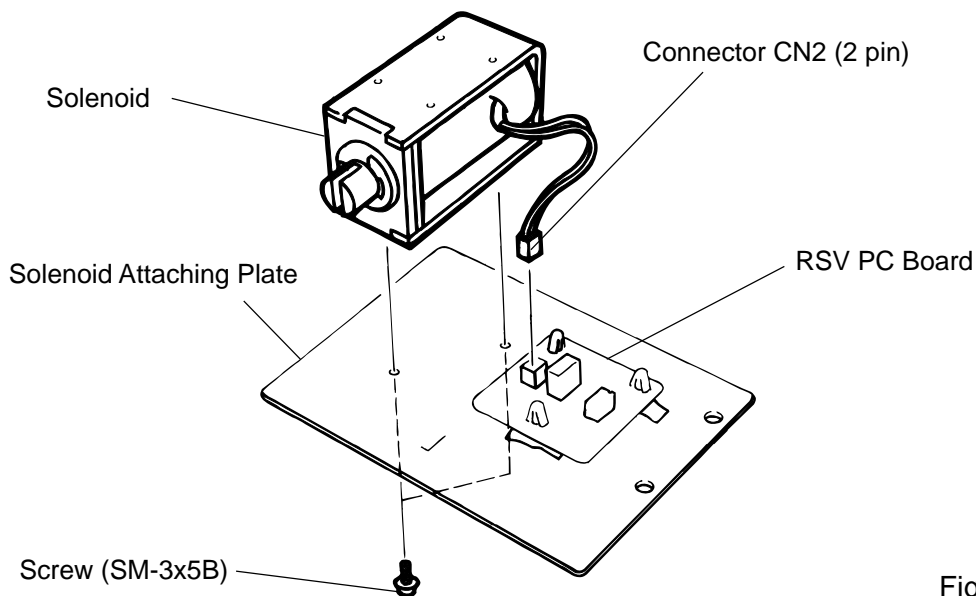

Fig. 2-11

**NOTE:** Make sure to remove any dust that appears during removal or installation because it may affect the print quality.

- 4) Replace the solenoid and attach it to the solenoid attaching plate.
- 5) Assemble the solenoid unit so that the head up link engages the spring pin.

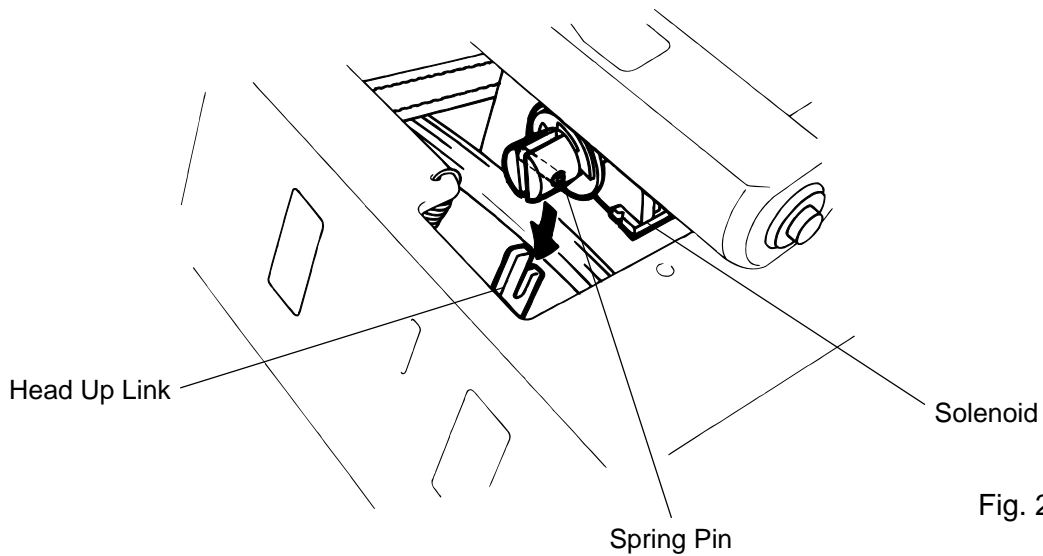

Fig. 2-12

**CAUTION:**

Take care to orient the screws so that they are vertically aligned with the solenoid attaching plate.

- 6) Reassemble in the reverse order of removal.

## 2.6 REPLACING THE PRINT HEAD

### CAUTION:

1. NEVER touch the element when handling the print head.
2. NEVER touch the connector pins to avoid a breakdown of the print head by static electricity.
3. NEVER remove the two screws painted red on the side of the print block.
4. NEVER remove the four screws on the side of the print block.
5. NEVER remove the print block, otherwise it requires the adjustment of the position when reassembling.

**NOTE:** The following procedure can be employed without removing the top cover and the left side cover.

- 1) Turn the head lever clockwise to lower the print head. Remove the two SM-4x8B screws.
- 2) Turn the head lever counterclockwise and disconnect the two connectors to detach the print head from the print block.

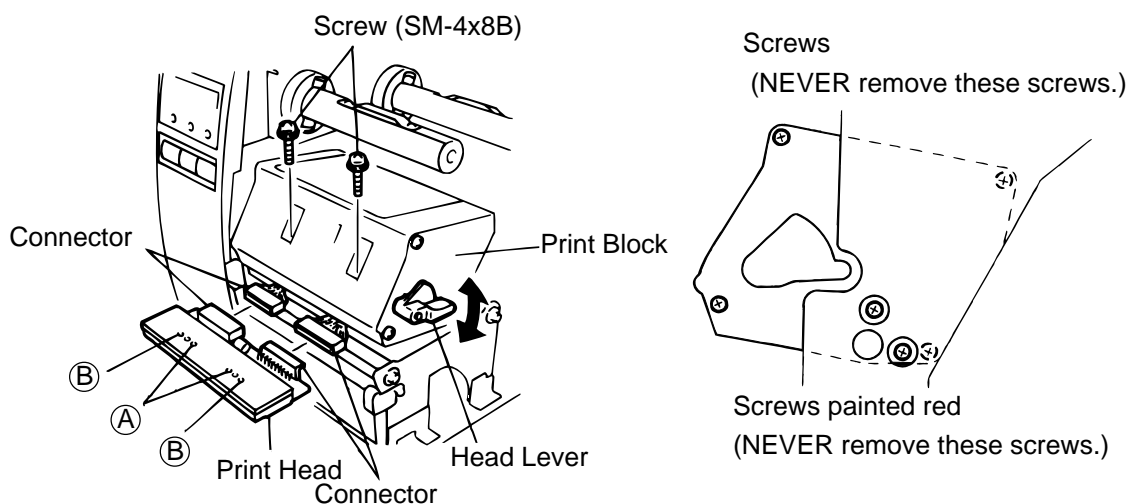

Fig. 2-13

- 3) Replace the print head and connect the connectors.
- 4) Align the two holes (A) in the middle of the print head with the print head position adjusting pins provided in the print block and fit the print head into the print block.
- 5) Turn the head lever clockwise and secure the print head at the other holes (B).
- 6) Refer to page 6-43 and clear the maintenance counter.
- 7) Refer to page 6-31 and perform test print.

**NOTE:** Use caution to prevent damage to the element during adjustment of the print head.

### ■ Adjusting the print head position

When print tone becomes light from using special paper with improper print head position, please follow the procedure below and adjust the print head position.

### NOTE:

Never loosen screws (C) unless print position fine adjustment is required because they have been adjusted properly. Doing so will change the adjustment.

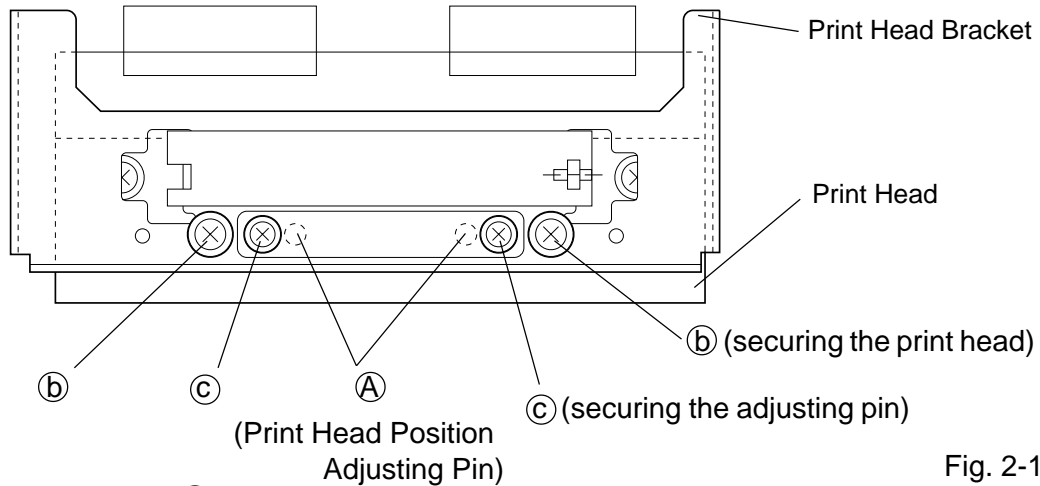

Fig. 2-14

- (1) Loosen the screws (c) securing the print head position adjusting pin.
- (2) Loosen the screws (b) one by one, slightly move the print head backward or forward, and then tighten the screws (b) and (c). Ensure that the print head is parallel to the platen. If not, print tone will be uneven.
- (3) Make a test print and if necessary, repeat Step 2) until the printer prints properly.

## 2.7 REPLACING THE PLATEN AND FEED ROLLER

### CAUTION:

1. NEVER remove the four screws painted red fixing the right plate and reinforcing plate. (See Fig. 2-15)
2. The pinch roller belt assembled inside the printer does not need to be replaced because it receives less load.

- 1) Remove the front plate and belt cover. (See Fig. 2-6.)
- 2) Disconnect the connector for the strip sensor (LED).
- 3) Remove the six screws (FL-4x6, B-4x12 and P-3x8) to detach the right plate ass'y.

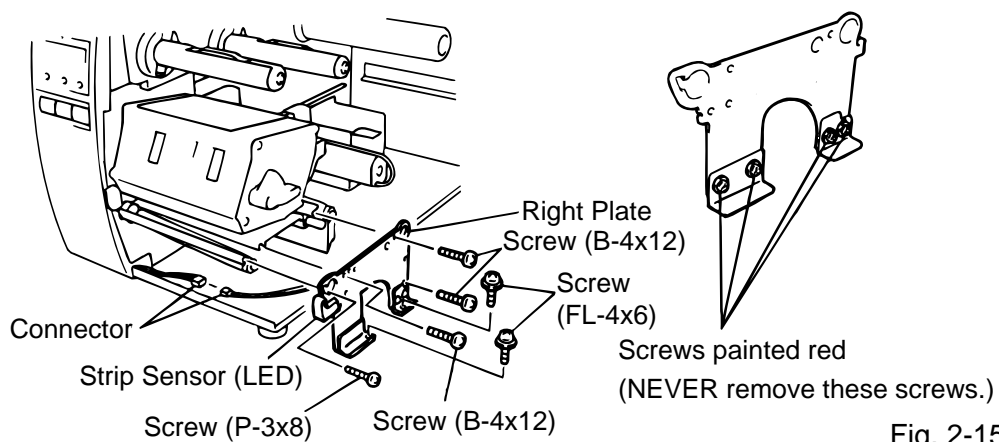

Fig. 2-15

**NOTE:** The machine with a serial number of 4T x x x x x or later is not equipped with the red screws because of the change in the right plate shape.

- 4) Loosen the two screws (SM-4x8B) fixing the stepping motor to loosen the platen belt and feed roller belt.
- 5) Remove the platen belt to detach the platen. Remove the feed roller belt to detach the feed roller.
- 6) Remove both bearings from the platen or feed roller.

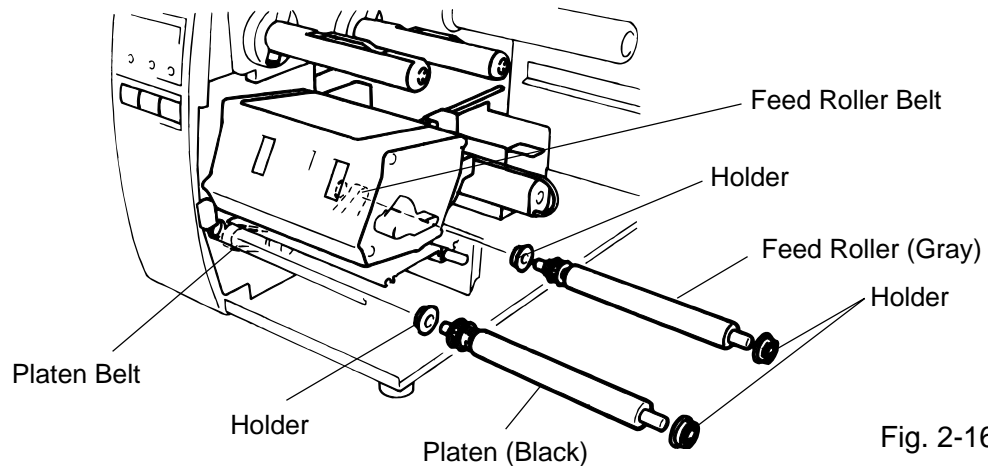

Fig. 2-16

- 7) Replace the platen and feed roller, put on the belt and assemble it with the printer. The longer belt is the platen belt.
- 8) Attach the right plate.
- 9) Hold down the stepping motor and secure it so that the belts have no slack or disengagement.
- 10) Reassemble in the reverse order of removal.

## 2.8 REPLACING THE PAPER SENSOR

**NOTE:** Turn the knob until the paper sensor reaches full forward.

- 1) Disconnect the connector for the strip sensor (LED) to remove right plate. (See Fig. 2-15.)
- 2) Disconnect the connectors for the paper sensor and sensor unit.
- 3) Remove M1.5 E-ring, turn the knob counter clockwise, then remove the paper sensor.

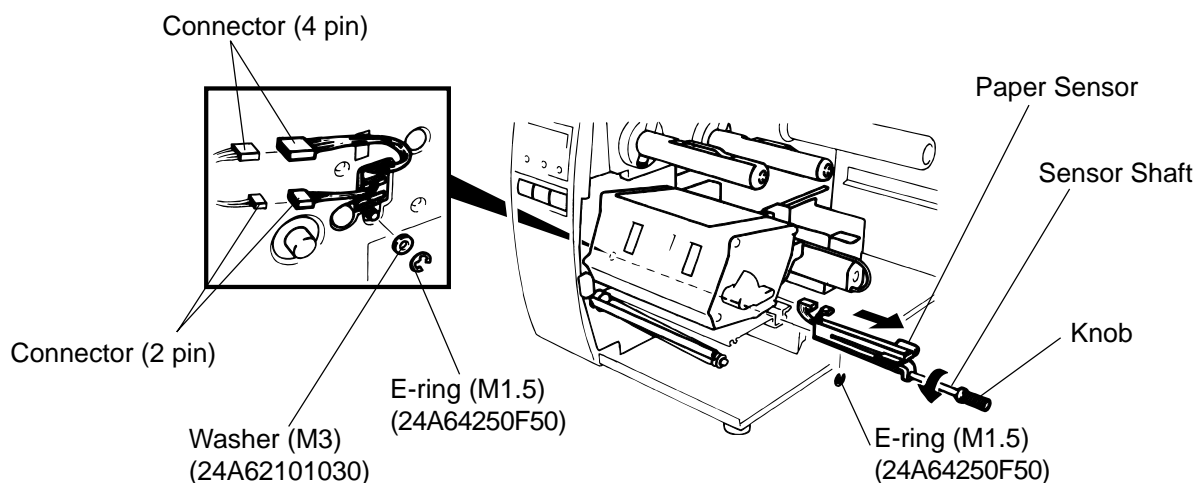

Fig. 2-17

- 4) Replace the paper sensor and reassemble in the reverse order of removal.
- 5) After replacing the paper sensor, refer to page 6-34/6-35 and adjust the voltage.

## 2.9 REPLACING THE RIBBON BACK TENSION BLOCK

- 1) Turn the head lever counterclockwise, then release the ribbon shaft holder plate.
- 2) Remove the M3 E-ring and the two M3 washers to remove the ribbon back tension block. At this time, remove the back tension stopper and ribbon back tension washer from the ribbon back tension block.

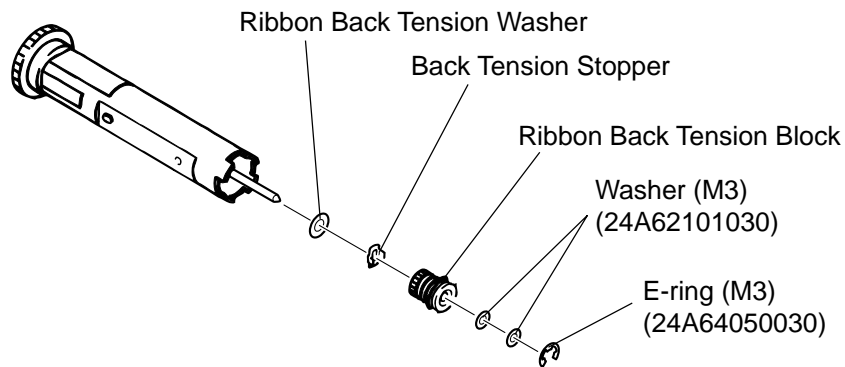

Fig. 2-18

- 3) Replace the back tension block and reassemble in the reverse order of removal.

## 2.10 REPLACING THE PINCH ROLLER SHAFT ASS'Y

- 1) Turn the head lever to position ③, and release the ribbon shaft holder plate.
- 2) Remove the black screw to detach the media guide plate.

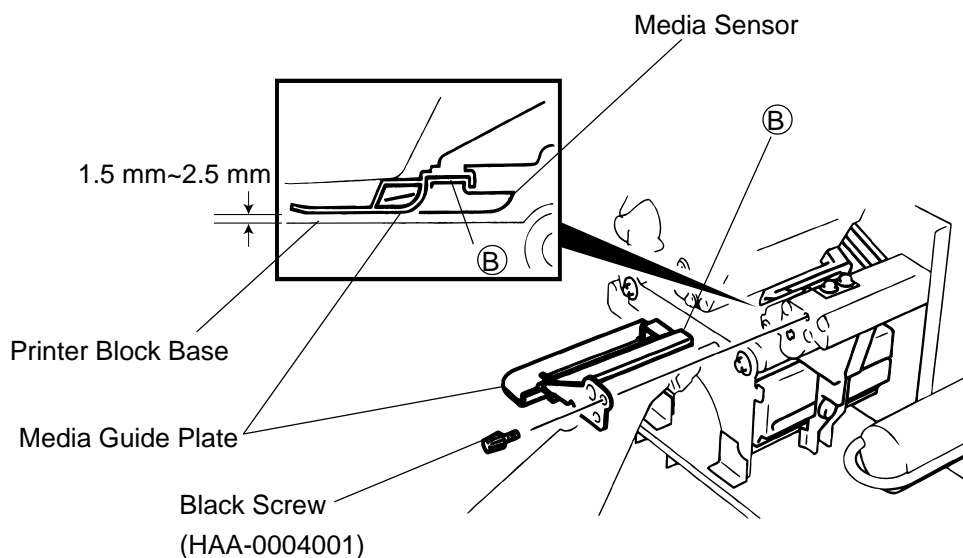

Fig. 2-19

- 3) Remove the SM-4x8B screw to detach the spring plate.
- 4) Remove the six B-4x12 screws to detach the pinch roller cover.
- 5) Remove the E-5 E-ring to loosen the pinch roller belt, and remove the pinch roller shaft ass'y.

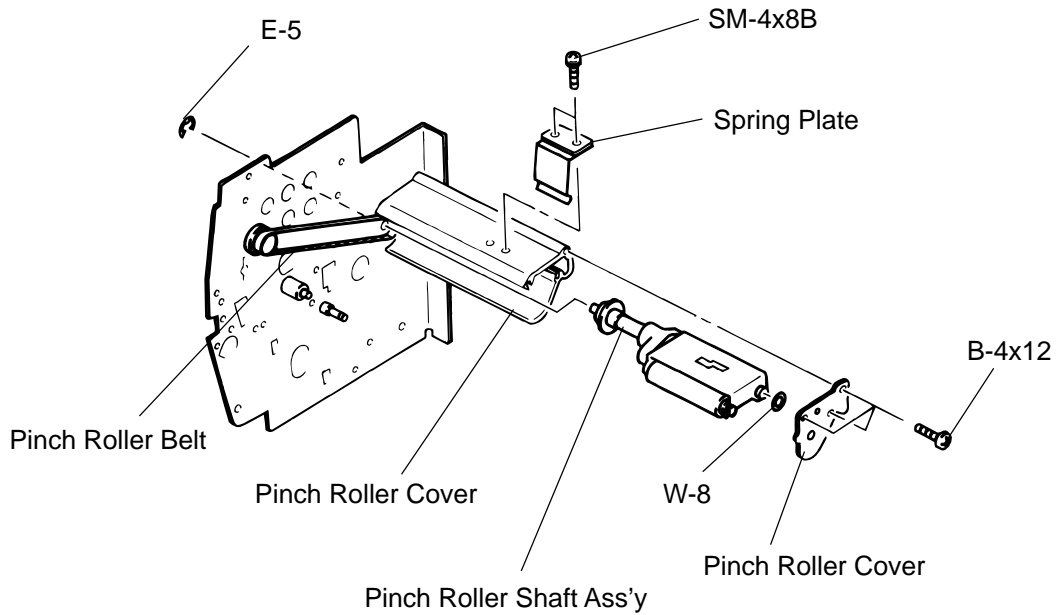

Fig. 2-20

- 6) After replacing the pinch roller shaft ass'y, make the following adjustment while you reassemble the pinch roller shaft ass'y in the reverse order of removal.

■ **Adjustment**

1. Install the pinch roller unit so it parallels the base. If it does not, change the engaging position of the pinch roller belt and the pulley.

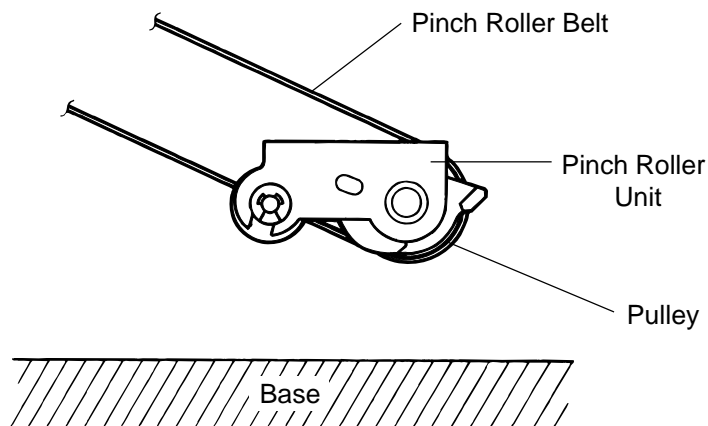

Fig. 2-21



- Attach the jig to the platen, feed roller and pinch roller shaft as shown in the figure below. Then attach the pinch roller cover to the pinch roller frame with the three B-4x12 screws. Then secure the pinch roller frame with the three B-4x12 screws.

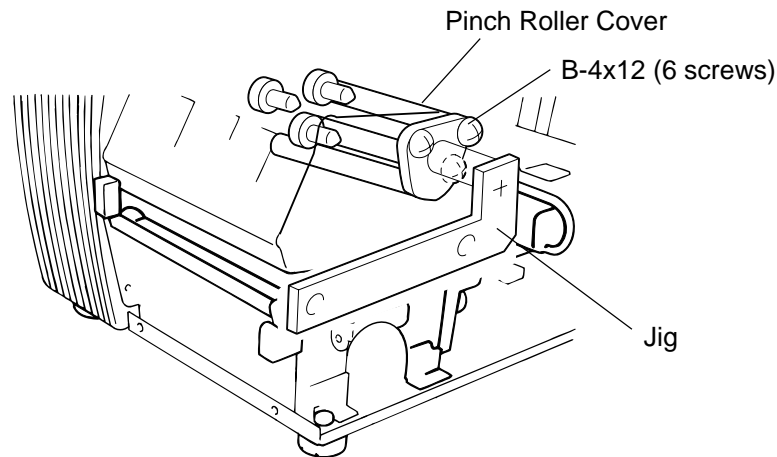

Fig. 2-22

- NOTES:**
- Replace the platen and the feed roller prior to attaching the jig.
  - Attach the jig while the pinch roller frame is tentatively attached to the main frame with the B-4x12 screws. Secure the pinch roller cover to the pinch roller frame with the three B-4x12 screws, then tighten the other side of the screws.
  - The flat top of the pinch roller frame must be installed in parallel to bosses on the printer frame.

**Check**

- Check if excessive load is applied to the jig after the above NOTE 2.  
(For example, check if the pinch roller frame moves when the jig is removed.)
  - Check that there is no gap caused by a slant shaft between the pinch roller and the feed roller when the pinch roller is lowered.
- Turn the head lever clockwise to lock the pinch roller shaft ass'y. Attach the spring plate to the pinch roller frame with the two SM-4x8B screws, pushing the spring plate toward the rear of the printer.

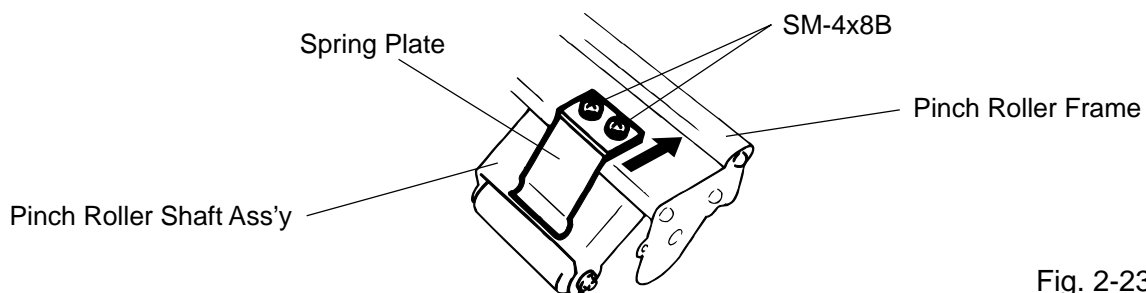

Fig. 2-23

- NOTE:** Check that the pinch roller shaft ass'y moves up and down smoothly when turning the head lever clockwise and counterclockwise.

- Install the media guide plate to the printer so there is a 1.5 to 2.5 mm gap between the media guide plate and the printer block base.

## 2.11 CORRECTING SKEW PRINTING

- If media still skews after adjusting the pinch roller shaft ass'y with the jig, follow the procedure below to correct the skew problem.
  1. Check if the media skews right or left.
  2. Loosen the B-4x12 screw to move the pinch roller cover to the front or rear of the printer depending on the skew direction.

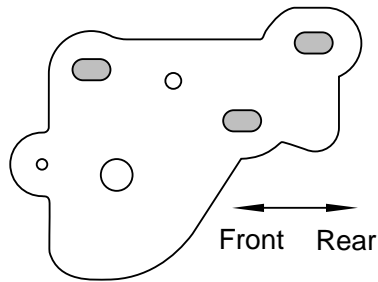

Fig. 2-24

When the media skews right, move the pinch roller cover to the front.

When the media skews left, move the pinch roller cover to the rear.

- If a paper skew problem should occur when using rolls would with labels facing outside after completing the modification, adjust the paper guide as follows.
  - \* In case the label skews to the right side of the print head, move the guide downward.
  - \* In case the label skews to the left side of the print head, move the guide upward.

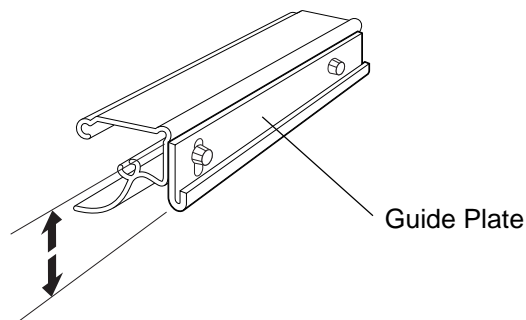

Fig. 2-25

## 3. INSTALLATION PROCEDURE FOR THE OPTIONAL EQUIPMENT

### WARNING!

Make sure to unplug the power cord before installing the optional equipment.

### 3.1 HIGH SPEED PC INTERFACE BOARD (B-4800-PC-QM)

The high speed PC interface board can be used together with the IBM PC-AT or its compatible machine only.

Description	Q'ty/Unit	Description	Q'ty/Unit
BPE PC board	1	Locking support	2
BPC PC board	1	Program diskette	1
Printer cable	1	Owner's Manual	1
Cable support	1		

1. Remove the top cover and left side cover. (See Fig. 2-1.)
2. Remove the two FL-3x5 screws to detach the blind plate.
3. Pass the printer cable through the opening.
4. Fasten the ground wire of the printer cable to the CPU PC board at the upper right with the SM-3x6B screw securing the CPU PC board.
5. Attach the two locking supports to the main frame plate. Install the BPE PC board aligning with the connector (CN15) and locking supports.

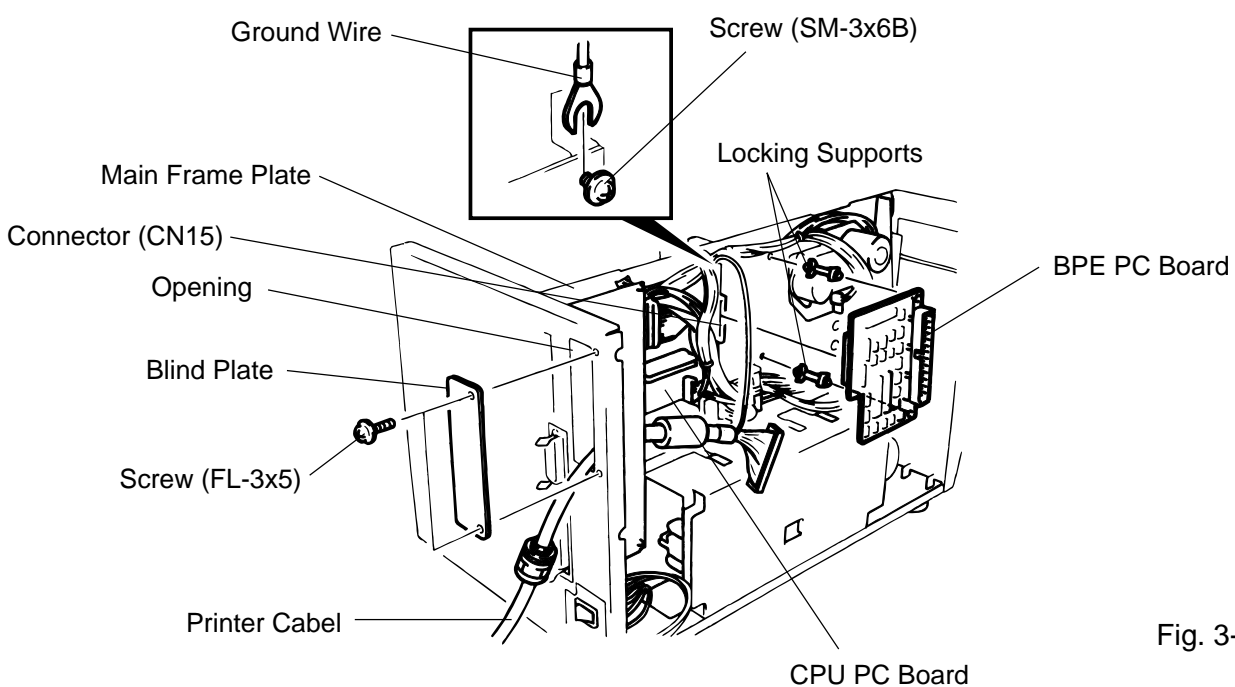

Fig. 3-1

6. Connect the printer cable to the connector (CN1) on the BPE PC board.
7. Put the cable strain relief of the printer cable in the notch of the cable support plate. Secure the cable strain relief to the cable support plate by turning the nut.
8. Attach the cable support plate to the printer with the FL3x5 screws removed in step 2.

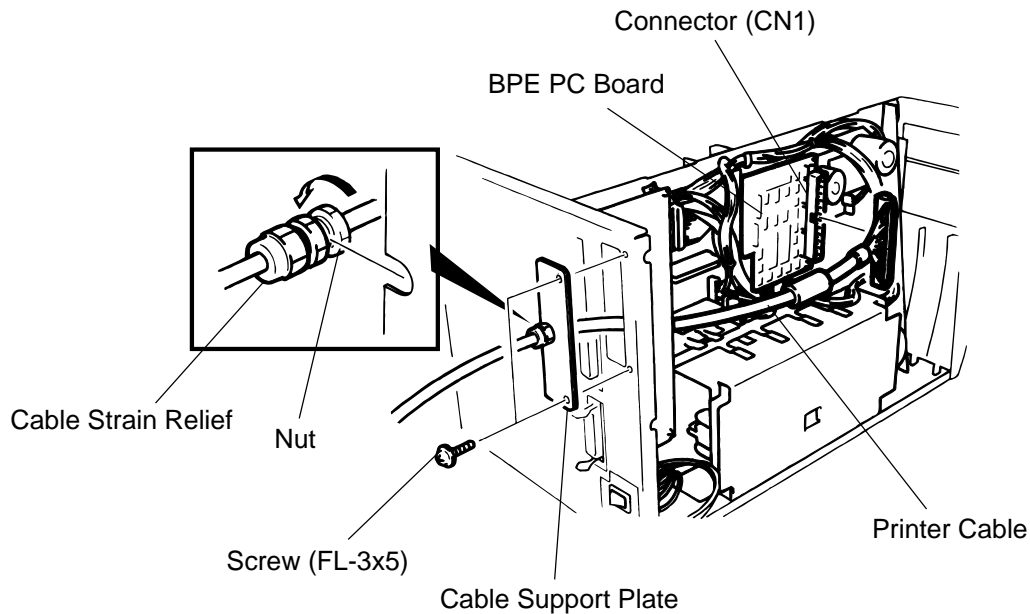

Fig. 3-2

9. Reassemble in the reverse order of removal.
10. Following procedure should be employed with your PC after this.
11. Set the DIP SW. on the BPC PC board for the I/O address according to your PC.
12. Install the BPC PC board on the expansion port bus line of your PC.
13. Connect the printer cable mentioned in step 5 to the BPC PC board.
14. Insert the attached FDK into the FDD and install the data in the hard disk. Since the installation procedure is different between MS-DOS™ and Windows™, refer to each owner's manual.
15. Perform a motion check.

\* Microsoft Windows and MS-DOS are registered trademark of Microsoft Corporation.

### 3.2 CUTTER MODULE (B-4203-QM)

Description	Q'ty/Unit	Description	Q'ty/Unit
Cutter Unit	1	Cutter Attaching Screw	2
Cutter Cover	1	Screw (FL-4x6)	1
Take-up/Cutter Harness	1	Cleaner	1

1. Remove the top cover and left side cover. (See Fig. 2-1.)
2. Remove the I/F PC board. (See Fig. 2-2.)
3. Remove the front plate. (See Fig. 2-6.)
4. Remove the screw (SM-4x8B) and two connectors to detach the operation panel.

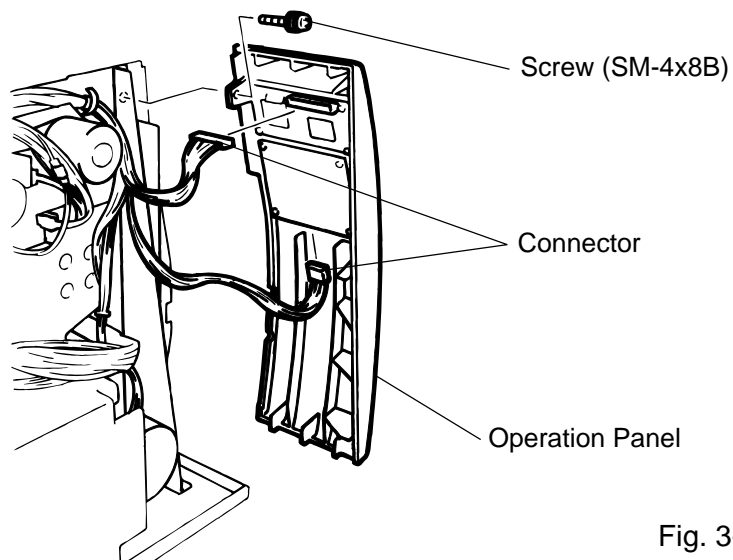

Fig. 3-3

5. Unclamp and disconnect the connector for the strip sensor from CN5 on the CPU PC board.
6. Remove the SM-4x6B screw to detach the strip sensor (LED)/(Tr).

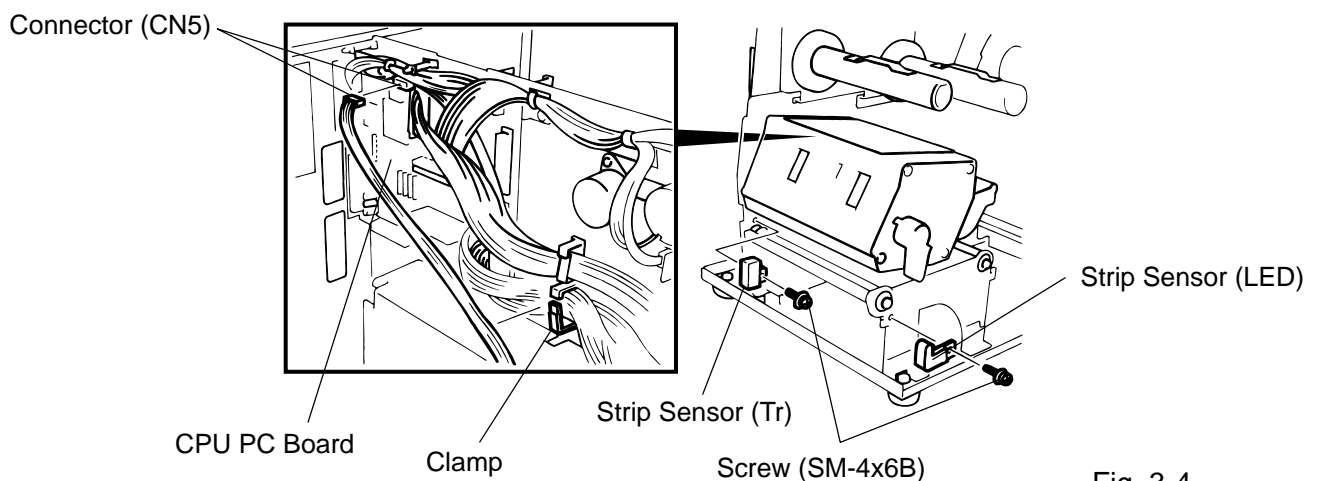

Fig. 3-4

### 3. INSTALLATION PROCEDURE FOR THE OPTIONAL EQUIPMENT

EM18-33012  
SVO7A1003: Nov. 21 '97  
3.2 CUTTER MODULE (B-4203-QM)

7. Remove the motor cover. (See Fig. 2-9.)
8. Disconnect the connector from CN2 on the PWM PC board.

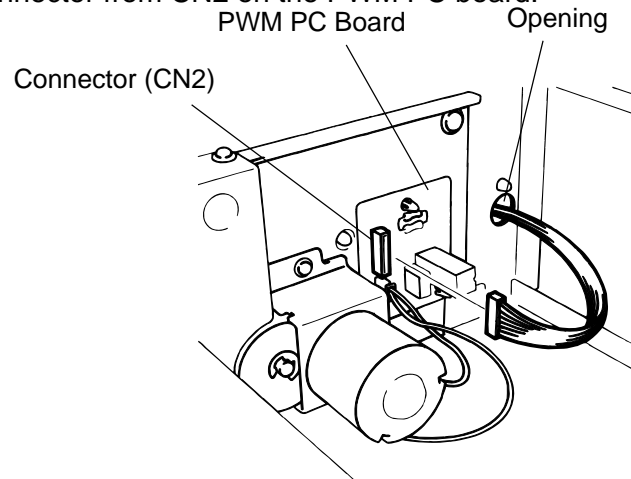

Fig. 3-5

9. Clamp and pass the cable through the opening and connect it to the CN1 on the Cutter I/F PC board.

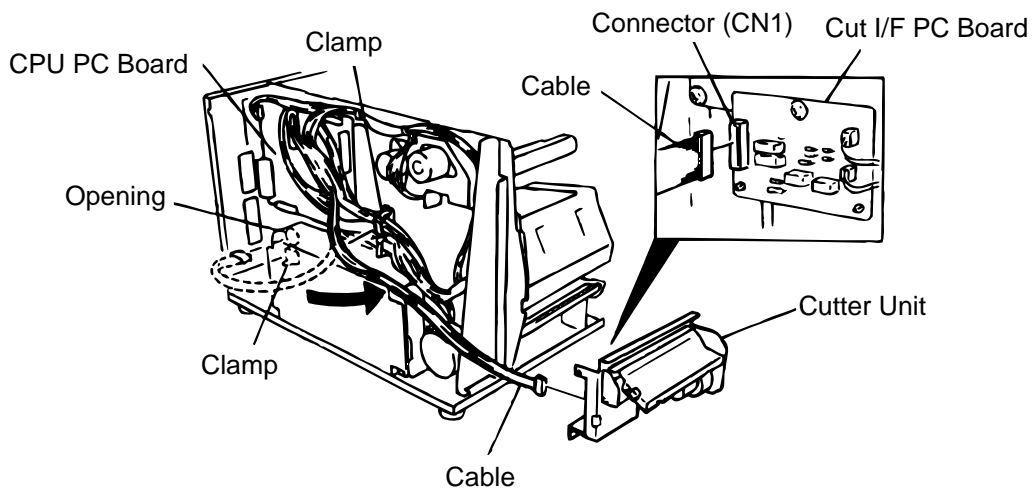

Fig. 3-6

10. Install the cutter unit with the attached screws (cutter attaching screw, FL-4x6).  
When installing the cutter, make sure that the cutter guide is not in contact with the platen. If it is, print failure or noise may be caused.

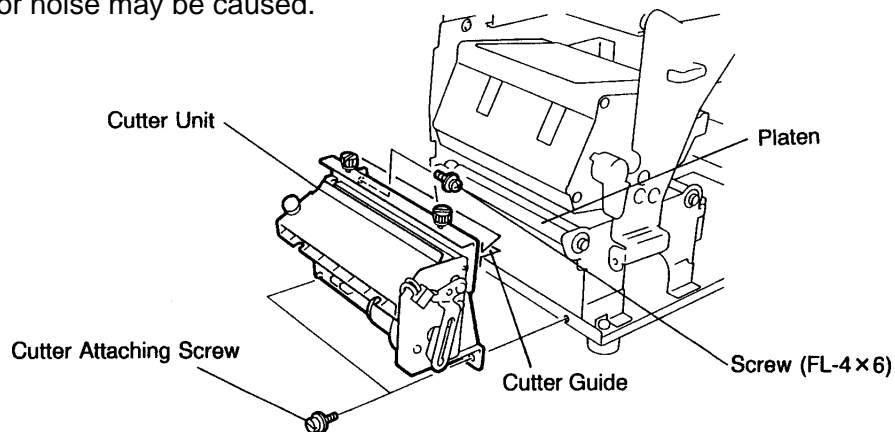

Fig. 3-7

11. Mount the cutter cover with the two screws.

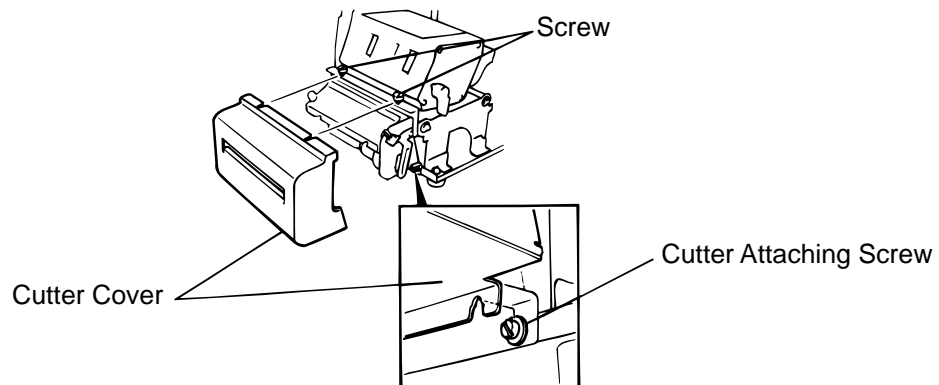

Fig. 3-8

12. Reassemble the motor cover, rewind full sensor (Tr), I/F PC board, left side cover and top cover in order.

13. After reassembly is complete, perform a test print to confirm that the cutter works properly.

After printing a print sample at a speed of 8"/sec., feed the media about 33 mm and check that the swing cutter works without error. After cutting the media, feed the media about 33 mm in the reverse direction and check that it correctly stops at the print start position.

- NOTES:**
1. If the top edge of label winds onto the platen in cut issue, set DIP SW. 1-5 to ON. (Refer to the Owner's Manual.)
  2. Retain the parts that are removed during installation of the cutter unit. They will be required when the printer is modified to a standard type.

Removed Parts	Q'ty/Unit	Removed Parts	Q'ty/Unit
Front plate	1	Strip sensor (LED)/(Tr)	1
Black screws	2	Screw (P-4x6)	2

■ **Adjusting the Cutter Guide Plates**

After replacing the cutter unit the following adjusting procedure should be employed to prevent paper jams.

1. Attach the cutter guide plate A with two SM-4x6C screws so that the fixed cutter is positioned 0.1 mm to 0.4 mm above the bottom of the cutter guide plate A.
2. Attach the cutter guide plate B with two FL-4x8 screws so that there is a clearance of 0.5 mm between the cutter guide plate A and cutter guide plate B using a clearance gauge.

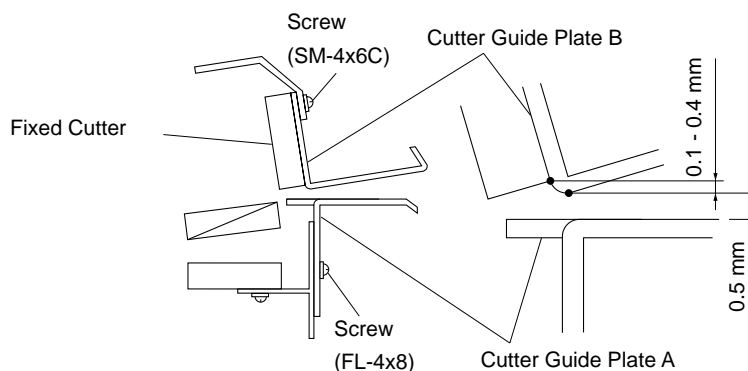

Fig. 3-9

**3.3 MEMORY MODULE**

1. Remove the top cover and left side cover. (See Fig. 2-1.)
2. Hold the memory module so that the Pin 1 is on the upper right, then attach the memory module to the IC socket. Expanding the memory must be performed in sequence, IC18, 19 and IC20.

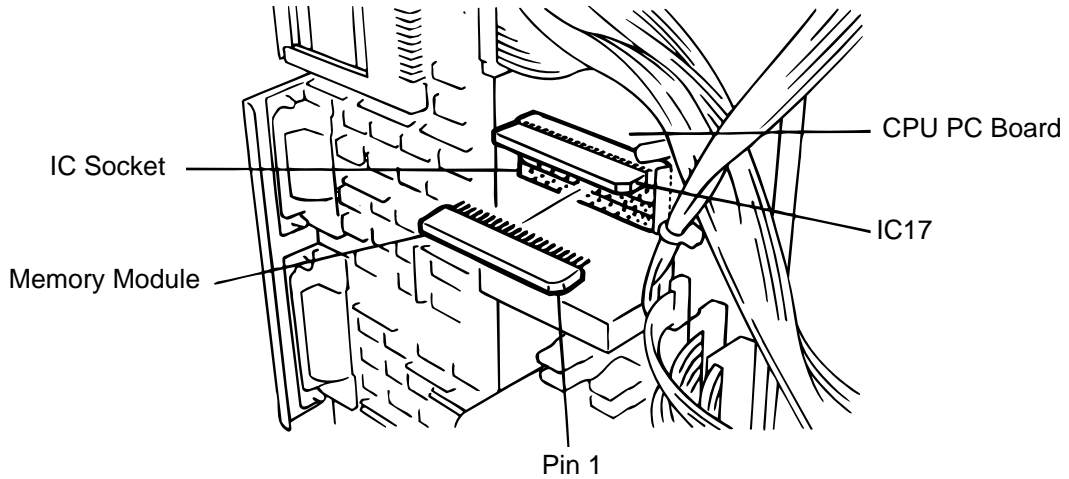

Fig. 3-10

3. Reassemble the left side cover in the reverse order of removal.

■ **Expansion memory and drawing size**

RAM Capacity	IC No.	Max. drawing size (normal) (W)x(H) (mm)			Max. drawing size (on-the-fly) (W)x(H) (mm)			Remarks
		Batch	Strip	Auto-cut	Batch	Strip	Auto-cut	
512kB	IC17	79.68 x 256.0			79.68 x 128.0			Standard
1MB	IC17, 18	79.68 x 597.4			79.68 x 298.0			Option
1.5MB	IC17 ~ 19	79.68 x 938.8			79.68 x 469.4			Option-
2MB	IC17 ~ 20	*79.68 x 995.0		*79.68 x 991.0	79.68 x 640.0			Option

\*: The size for the tag paper is 79.68 x 997.0.



**3.4 FANFOLD PAPER GUIDE MODULE (B-4903-FF-QM)**

Description	Q'ty/Unit
Fanfold Paper Guide(rear)	1
Fanfood Paper Guide (front)	1

1. Open the top cover.
2. Remove the T-4x8 screws to detach the paper guide ass'y at the center of the printer and attach the fanfold paper guide (front) with these same screws.

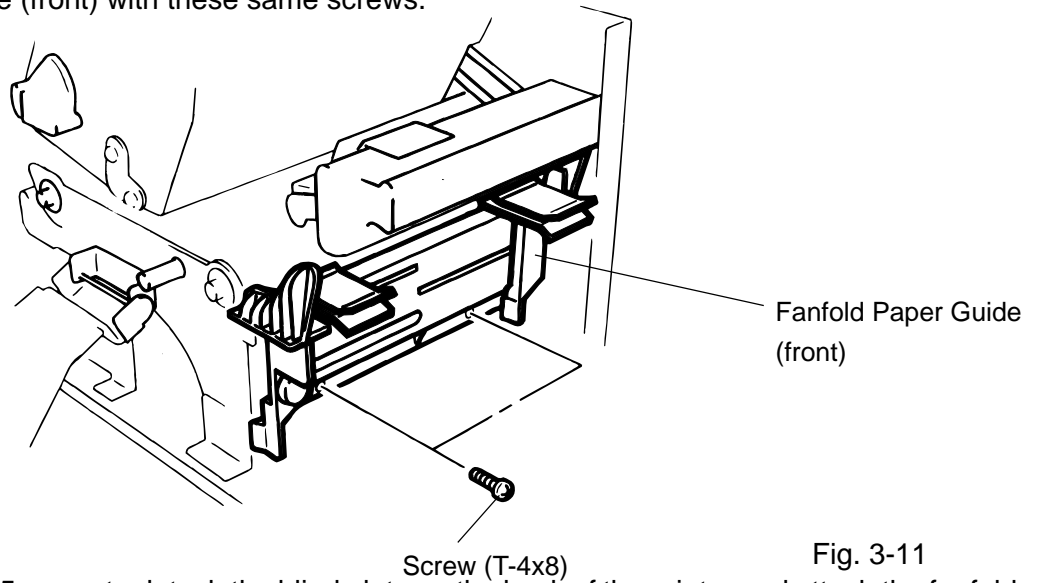

Fig. 3-11

3. Remove the FL-4x5 screw to detach the blind plate on the back of the printer and attach the fanfold paper guide (rear) with the same screw.

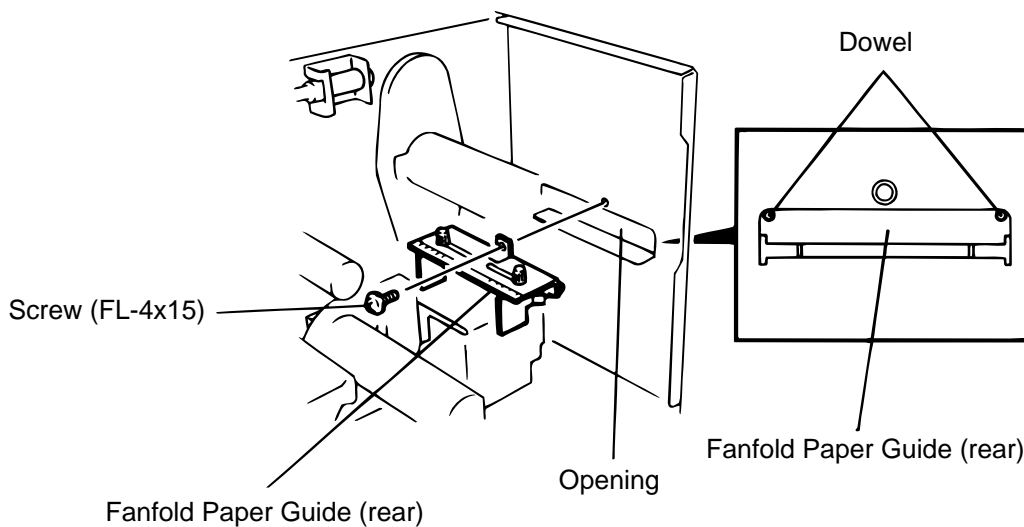

Fig. 3-12

**NOTE:** When installing the fanfold paper guide (rear), fit the dowels to the upper corners of the opening.

# 4. MECHANISM DESCRIPTION

## 4.1 CUTTER DRIVE (CUTTER MODE)

The printer supplies DC + 27 V to the cutter motor to rotate the cutter motor and clutch counter clockwise. The arm swings like a pendulum and moves the fixed slide cutter up and down to make a cut.

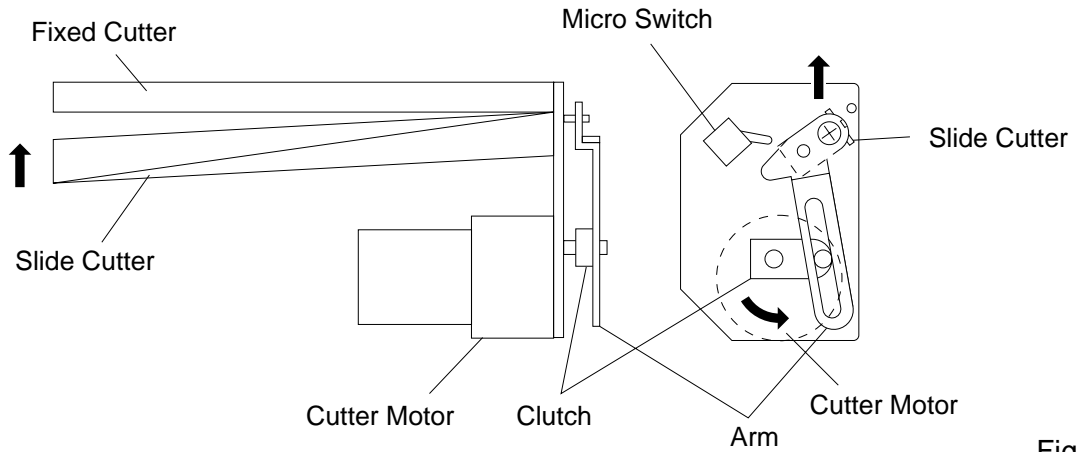

Fig. 4-1

After making a cut, the arm turns the micro switch off and the cutter home position is detected. When the cutter does not return to the home position because of a paper jam, an error occurs and the next piece of paper will not be cut.

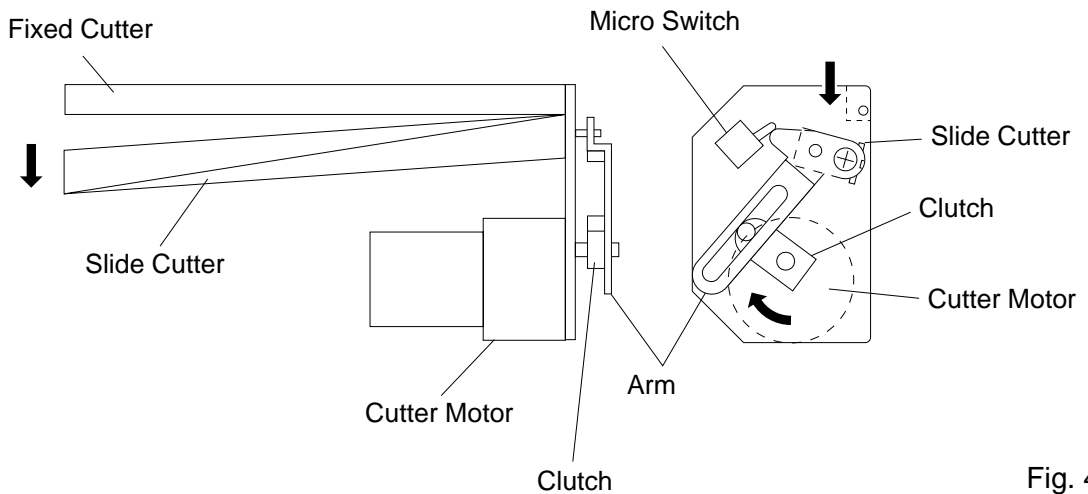
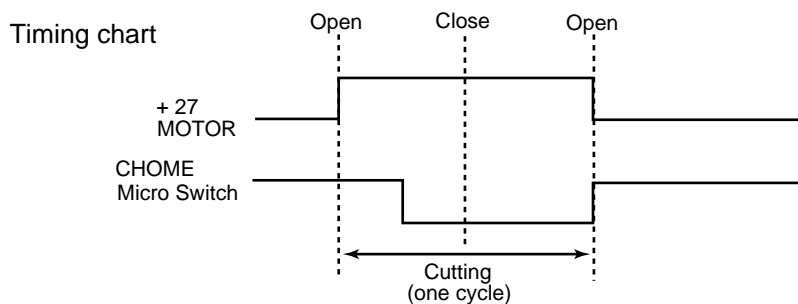

Fig. 4-2



4.2 HARNESS WIRING

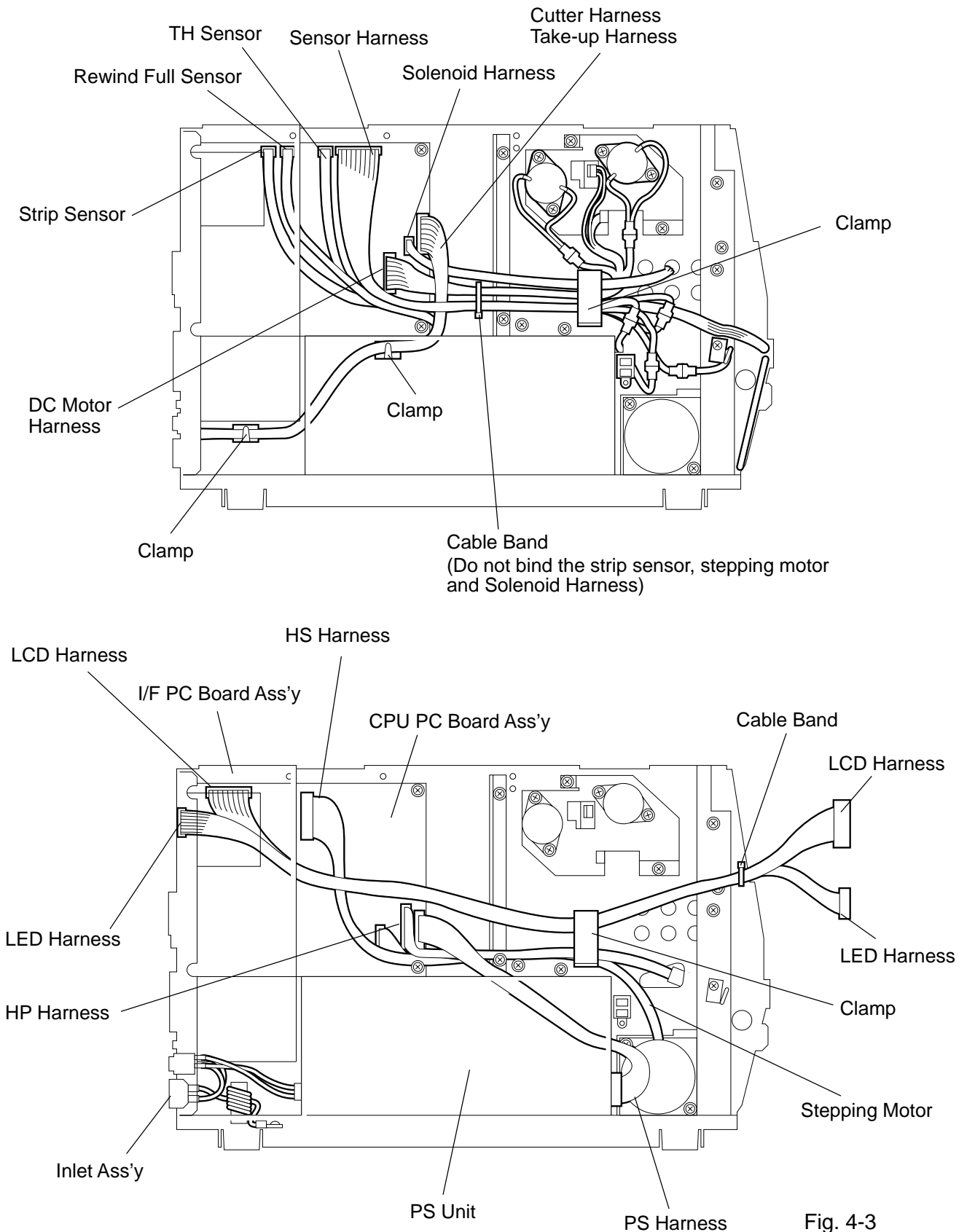

Fig. 4-3

## 5. TROUBLESHOOTING

Problems	Cause	Solution
Power is not turned ON.	<ol style="list-style-type: none"> <li>1. Input voltage to the printer is not within the rated voltage. (Check by CN1 on the PS unit.)</li> <li>2. Output voltage from the printer is not within the rated voltage. (Check that the voltage between Pin 4 and Pin 6 (GND) of CN2 on the PS unit is 27 V. And check the voltage between Pin 1 and Pin 3 (GND) is 5 V.)</li> <li>3. CPU PC board is not applied with voltage. (Check the voltage between Pin 1 and Pin 3 (GND) of the CN17 on the CPU PC board is 27 V.)</li> <li>4. Failure of CPU PC board.</li> </ol>	<ul style="list-style-type: none"> <li>• Replace the power cable or power inlet.</li> <li>• Replace the PS unit.</li> <li>• Replace the power harness.</li> <li>• Replace the CPU PC board.</li> </ul>
LED or LCD does not light.	<ol style="list-style-type: none"> <li>1. Failure of the LED board/LCD</li> <li>2. Failure of the LCD/LED harness</li> <li>3. Failure of the CPU PC board</li> </ol>	<ul style="list-style-type: none"> <li>• Replace the LED board/LCD.</li> <li>• Replace the LCD/LED harness.</li> <li>• Replace the CPU PC board.</li> </ul>
Poor printing	<ol style="list-style-type: none"> <li>1. The print paper is of poor quality.</li> <li>2. Dirty print head</li> <li>3. The head lever fastens the print head incompletely.</li> <li>4. Alignment adjustment of the print head is improper.</li> </ol>	<ul style="list-style-type: none"> <li>• Use the media approved by TOSHIBA TEC.</li> <li>• Clean the print head.</li> <li>• Fasten the head lever completely.</li> <li>• Re-adjust the print head.</li> </ul>
Printer does not print.	<ol style="list-style-type: none"> <li>1. Print head failure</li> <li>2. Connection of the print head connector is incomplete, a bad contact, or broken wires.</li> <li>3. Failure in rewinding/feeding of the ribbon.</li> <li>4. Failure of the CPU PC board</li> <li>5. Failure of the software</li> <li>6. Failure of the printer cable</li> </ol>	<ul style="list-style-type: none"> <li>• Replace the print head.</li> <li>• Connect the harness completely, or replace the harness.</li> <li>• Replace the ribbon rewind motor, ribbon feed motor or CPU PC board.</li> <li>• Replace the CPU PC board.</li> <li>• Check the program.</li> <li>• Replace the printer cable.</li> </ul>

Problems	Cause	Solution
Dot missing	<ol style="list-style-type: none"> <li>1. Broken element of print head</li> <li>2. Broken wires of print head cable</li> <li>3. Failure of the CPU PC board</li> </ol>	<ul style="list-style-type: none"> <li>• Replace the print head.</li> <li>• Replace the print head harness.</li> <li>• Replace the CPU PC board.</li> </ul>
Blurred print	<ol style="list-style-type: none"> <li>1. Poor quality of media.</li> <li>2. Dust is attached to the media.</li> </ol>	<ul style="list-style-type: none"> <li>• Use only TOSHIBA TEC specified media.</li> <li>• Clean the print head and remove the dust from the media.</li> </ul>
Ribbon wrinkle	<ol style="list-style-type: none"> <li>1. Poor quality of the ribbon</li> <li>2. Ribbon is not rewound or fed smoothly.</li> </ol>	<ul style="list-style-type: none"> <li>• Use only TOSHIBA TEC specified ribbon.</li> <li>• Replace the ribbon rewind motor or ribbon feed motor.</li> </ul>
Ribbon end error	<ol style="list-style-type: none"> <li>1. Poor quality of the ribbon.</li> <li>2. Improper voltage applied to the ribbon end sensor.</li> <li>3. Failure of the ribbon end sensor</li> <li>4. Failure of the circuit which controls the ribbon end sensor.</li> </ol>	<ul style="list-style-type: none"> <li>• Use only TOSHIBA TEC specified ribbon.</li> <li>• Refer to page 2-3 to adjust the ribbon end sensor.</li> <li>• Replace the ribbon end sensor.</li> <li>• Replace the CPU PC board.</li> </ul>
Label feed failure	<ol style="list-style-type: none"> <li>1. Paper is not set properly.</li> <li>2. Paper of poor quality</li> <li>3. Improper adjustment of the feed gap sensor or black mark sensor.</li> <li>4. Failure of the feed gap sensor or black mark sensor</li> <li>5. Labels cannot be stripped off the backing paper or the backing paper with labels cannot be wound properly.</li> <li>6. The cutter mechanism is not installed properly.</li> <li>7. Failure of the stepping motor</li> </ol>	<ul style="list-style-type: none"> <li>• Set the paper properly.</li> <li>• Use the paper approved by TOSHIBA TEC.</li> <li>• Re-adjust the sensor.</li> <li>• Replace the feed gap sensor or black mark sensor.</li> <li>• Replace the take-up motor or CPU PC board.</li> <li>• Install the cutter mechanism properly.</li> <li>• Replace the stepping motor or CPU PC board.</li> </ul>
Communication error	<ol style="list-style-type: none"> <li>1. Failure of the communication cable</li> <li>2. Failure of the RS-232C connector</li> <li>3. Failure of the communication connector</li> <li>4. Failure of the PC or application software</li> <li>5. Failure of the CPU PC board</li> </ol>	<ul style="list-style-type: none"> <li>• Replace the cable.</li> <li>• Replace the connector.</li> <li>• Replace the connector.</li> <li>• Modify the program.</li> <li>• Replace IC5 (MC145407). If the trouble is not solved, replace the CPU PC board.</li> </ul>

## TABLE OF CONTENTS

	Page
6. DIAG. TEST OPERATION .....	6- 1
6.1 OUTLINE OF THE DIAG. TEST OPERATION .....	6- 1
6.2 SELF TEST MODE .....	6- 3
6.2.1 Maintenance Counter Printing .....	6- 3
6.2.2 Automatic Diagnostic Printing .....	6- 6
6.2.3 Head Broken Element Check .....	6-12
6.3 PARAMETER SETTING MODE .....	6-13
6.3.1 Feed Length Fine Adjustment .....	6-15
6.3.2 Cut/Strip Postion Fine Adjustment .....	6-16
6.3.3 Back Feed Length Fine Adujstment .....	6-17
6.3.4 X Axis Fine Adjustment .....	6-22
6.3.5 Print Tone Fine Adjustment .....	6-24
6.3.6 Character Code Selection .....	6-25
6.3.7 Font Zero Selection .....	6-26
6.3.8 Control Code Selection .....	6-27
6.3.9 Ribbon Type Selection .....	6-29
6.3.10 Ribbon Motor Drive Voltage Fine Adjustment .....	6-30
6.3.11 Strip Wait Status Setting .....	6-31
6.3.12 Stacker Selection .....	6-32
6.3.13 Threshold Manual Fine Adjustment for the Black Mark Sensor .....	6-33
6.3.14 Threshold Manual Fine Adjustment for the Feed Gap Sensor .....	6-34
6.3.15 Kanji Code Selection .....	6-37
6.3.16 Euro Font Code Selection .....	6-38
6.3.17 Transmission Control Mode Selection .....	6-39
6.3.18 Reset Selection when the INPUT • PRIME Signal is ON .....	6-40
6.4 TEST PRINT MODE .....	6-41
6.4.1 Normal Test Print .....	6-41
6.4.2 Process Test Print .....	6-46
6.5 SENSOR SETTING MODE .....	6-48
6.5.1 Thermistor Check (Read only) .....	6-48
6.5.2 Black Mark Sensor Adjustment .....	6-49
6.5.3 Feed Gap Sensor Adjustment .....	6-50
6.5.4 Paper End Setting for Black Mark Sensor .....	6-51
6.5.5 Paper End Setting for Feed Gap Sensor .....	6-52
6.6 RAM CLEAR MODE .....	6-53
6.6.1 Maintenance Counter Clear .....	6-55
6.6.2 Parameter Clear .....	6-56

### **CAUTION:**

1. *This manual may not be copied in whole or in part without prior written permission of TOSHIBA TEC.*
2. *The contents of this manual may be changed without notification.*
3. *Please refer to your local Authorized Service representative with regard to any queries you may have in this manual.*

# 6. DIAG. TEST OPERATION

## 6.1 OUTLINE OF THE DIAG. TEST OPERATION

In system mode the diag. test operation is used to diagnose the printer and to set the parameters by using the [FEED], [RESTART] and [PAUSE] keys on the operation panel. Diag. test operation (Type I) is started from the power off state and the parameter setting (Type II) is started while the printer is on-line or printing. For further details, please refer to the corresponding pages.

**NOTE:** Every size in this manual is written in millimeter. To obtain the size in inch, divide by 25.4.

■ Type I

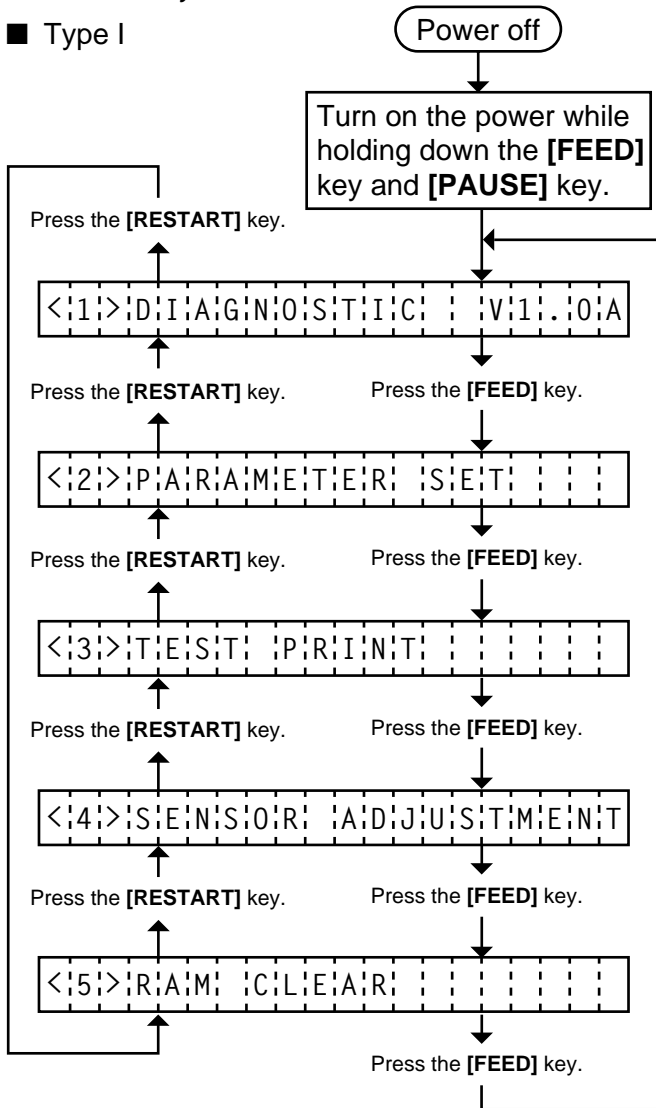

- Self Test Mode (See page 6-3)  
Data from the maintenance counter and automatic diagnosis are printed on the media. The result of the head broken element check is indicated in the display.
- Parameter Setting Mode (See page 6-13)  
Fine adjustment of the feed length, cut/strip position, back feed, X axis, print tone, and thresholds of the black mark sensor and feed gap sensor, and selection of character font, font zero, control code, ribbon type, ribbon motor torque, strip wait status, Euro font code, transmission control mode, reset ON/OFF when the INPUT • PRIME signal is ON and Stacker are available in this mode.
- Test Print Mode (See page 6-41)  
Print condition and test print type (slant line, characters and bar code) are selectable.
- Sensor Setting Mode (See page 6-48)  
A thermistor check and the setting of the black mark and feed gap sensors are available in this mode.  
A transmission check is made to both a print head thermistor and an environmental temperature thermistor.
- RAM Clear Mode (See page 6-53)  
Data from the maintenance counter is cleared and parameter setting is initialized in the RAM clear mode.

In system mode the [FEED], [RESTART] and [PAUSE] keys function as described below.

■ Key Function Table

Key Name	Function
[FEED] key	Used to start the system mode as the [PAUSE] key does. Used to select the parameter mode or to fine adjust the parameters in the negative direction(-).
[RESTART] key	Used to select the parameter mode or to fine adjust the parameters in the positive direction (+).
[PAUSE] key	Used to start the system mode as the [FEED] key does and to select the parameter mode. Used as an enter key.

■ Type II

The parameter setting such as feed length fine adjustment or cut/strip position fine adjustment can be changed while the printer is on-line or printing. Pressing the **[PAUSE]** key causes the printer to enter parameter setting mode. Reset mode is provided for this procedure to cancel the steps which follow the **[PAUSE]** key without turning the power off.

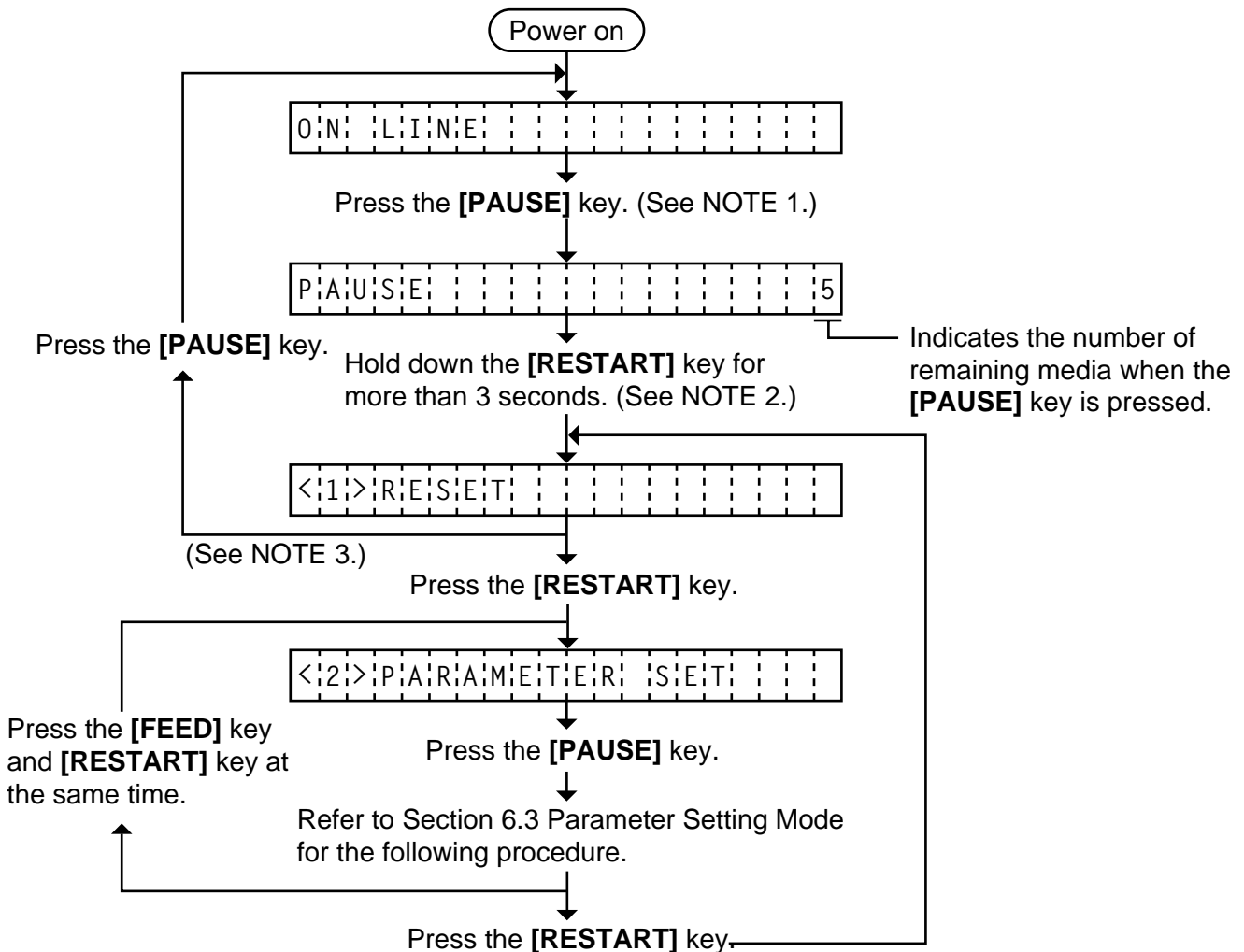

- NOTES:**
1. Pressing the **[PAUSE]** key during printing causes the printer to pause printing and show the number of remaining media.
  2. If the **[RESTART]** key is released within 3 seconds, the printer will resume printing because the **[RESTART]** key is activated.
  3. Since the reset is performed when terminating this mode, the printer cancels the remaining media and returns to on-line mode. This reset will not clear the changed parameter settings.



## 6.2 SELF TEST MODE

In self test mode the printer status is printed in two types of sample print. The result of the head broken element check is indicated in the display.

### 6.2.1 Maintenance Counter Printing

The data from 1 to 31 on a sample print is printed. This data is the printer status and the value set in the parameter setting mode.

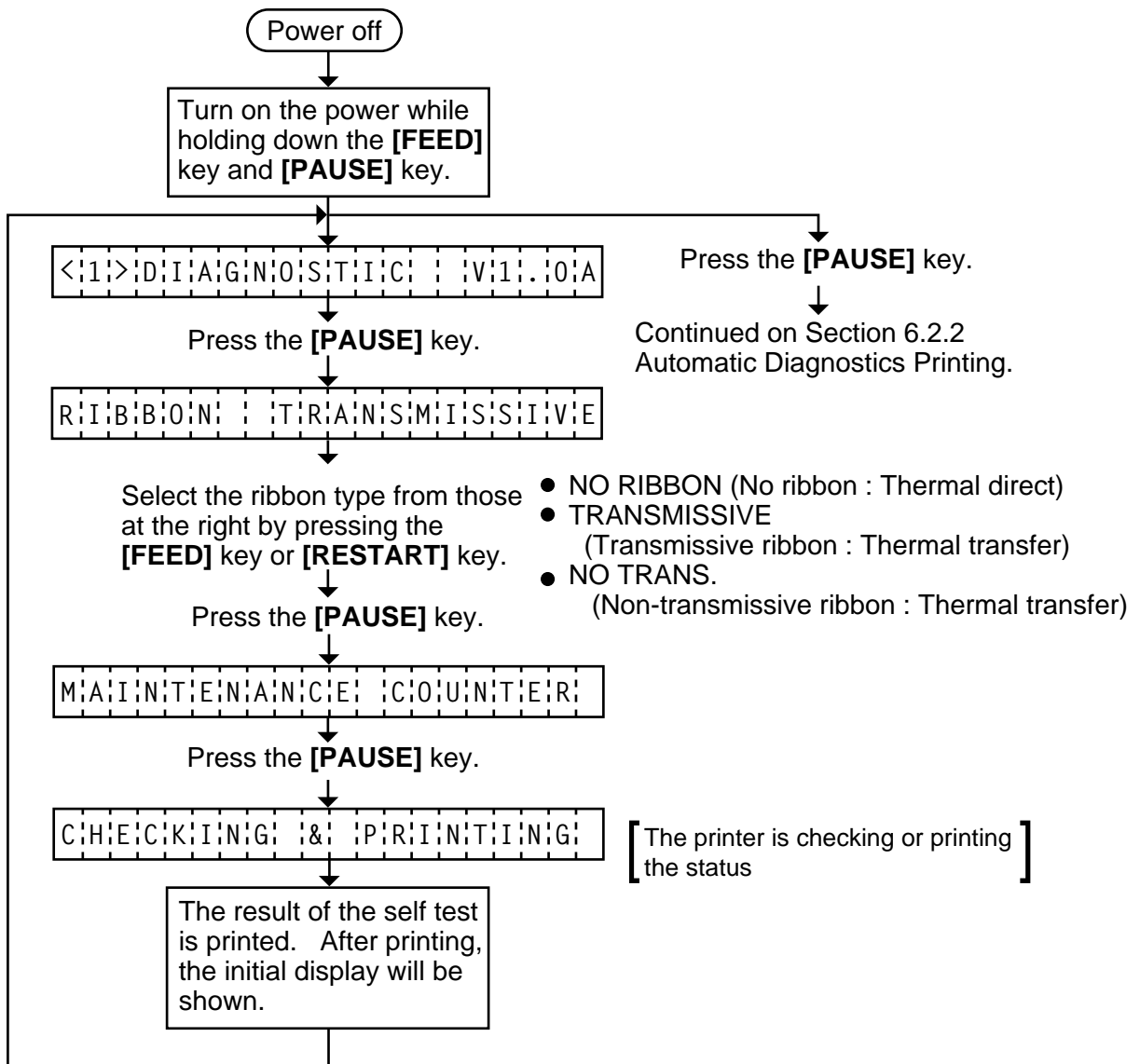

- NOTES:**
1. If the maintenance counter printing results in an error, the printer will display the error message and stop printing. The error status can be cleared by the [PAUSE] key, however, the display will return to the initial display "<1> DIAGNOSTIC V1.0A". Printing is not automatically resumed after the error is cleared.
  2. Both label and tag paper can be used for printing.

■ **Sample Print**

[Print Condition]

- Preset count : 1
- Print speed : 127 mm/sec.
- Sensor : No sensor
- Printing method : Thermal transfer
- Supply length : 50 mm
- Issuing mode : Batch printing  
(without rewinder)

(1)	TL FEED	1882.3km	[PC]	
(2)	FEED	20.5km	FEED	-10.0mm (14)
(3)	PRINT	15.0km	CUT	-5.0mm (15)
(4)	CUT	148150	BACK	+3.0mm (16)
(5)	HEAD U/D	170	TONE(T)	+3step (17)
(6)	RIBBON	32h	TONE(D)	+5step (18)
(7)	SOLENOID	0h	[KEY]	
(8)	232C ERR	1	FEED	+5.0mm (19)
(9)	SYSERR	0	CUT	-1.5mm (20)
(10)	PW FAIL	0	BACK	+0.5mm (21)
(11)	FONT	[PC-850] [0]	TONE(T)	+0step (22)
(12)	CODE	[ESC LF NUL]	TONE(D)	+1step (23)
(13)	RIBN	[TRANS.]	X ADJ.	+35.0mm (24)
(25)	RIBN ADJ. [PC] + 0 +0 [KEY] + 0 +0			
(26)	STATUS [OFF]			
(27)	THRESHOLD R 1.0V			
(28)	THRESHOLD T 1.4V			
(29)	KANJI [TYPE1]			
(30)	EURO CODE B0H			
(31)	STACKER [OFF]			
(32)	DTR/RTS [DTR]			
(33)	INPUT PRIME [ON]			

1) Maintenance Counter

Fig. 6-1

#	Item	Count Condition	Range
(1)	Total media distance covered	Counted when the feed motor drives to feed, print and issue the media. (Counted also during ribbon save operation and back feed.) [See NOTE 2].	0.0 ~ 3200.0 km
(2)	Media distance		0.0 ~ 200.0 km
(3)	Print distance	Counted while printing. (Feeding and issuing media, and ribbon saving operation are not counted.) [See NOTE 2.]	0.0 ~ 200.0 km
(4)	Cut count	Counts every cut. [See NOTE 3.]	0 ~ 1000000 times
(5)	Head up and down count	Counts every up and down of the print head using the solenoid for ribbon save operation. (Up + Down = 1 count) [See NOTE 3.]	0 ~ 2000000 times
(6)	Ribbon motor driving time	Counts when the ribbon motor drives to feed, print and issue the media. (The driving time is not counted during ribbon saving operation, but is during back feed.) [See NOTE 4.]	0 ~ 2000 hours
(7)	Solenoid driving time	Counted during ribbon saving operation. [See NOTE 4.]	0 ~ 1000 hours
(8)	RS-232C hardware error count	Counted when a parity, overrun or framing error occurs. [See NOTE 5.]	0 ~ 255 times
(9)	System error count	Counted when a zero-dividing error occurs or undefined command is retrieved.	0 ~ 15 times
(10)	Momentary power failure count	Counts the number of times the power restores while the CPU is busy after reset.	0 ~ 15 times

- NOTES:**
1. Item from (2) through (10) are initialized to "0" after RAM clear.
  2. If the distance is 5.5 m or less, it is rounded down and no data is added to the memory at power off.
  3. If the count is 31 counts or less, it is rounded down and no data is added to the memory at power off.
  4. If the driving time is 27 sec. or less, it is rounded down and no data is added to the memory at power off.
  5. When a sent command results in an error, the same number as the data capacity of the command is counted by byte.

## 2) Parameters

#	Item	Contents
(11)	Character code selection	PC-850 : PC-850 PC-8 : PC-8
	Font zero selection	0 : No slash used. Ø : Slash used.
(12)	Control code selection	AUTO : Automatic selection ESC LF NUL : ESC LF NUL mode {   } : Mainframe mode 1B 1C 1D : Manual mode
(13)	Ribbon type selection	TRANS. : Transmissive ribbon NON TRANS. : Non-transmissive ribbon
(14) (19)	Feed length fine adjustment (PC), (KEY)	-50.0 mm to +50.0 mm
(15) (20)	Cut/strip position fine adjustment (PC), (KEY)	-50.0 mm to +50.0 mm
(16) (21)	Back feed length fine adjustment (PC), (KEY)	-9.9 mm to +9.9 mm
(17) (22)	Print tone fine adjustment (Thermal transfer) (PC), (KEY)	-10 step to +10 step
(18) (23)	Print tone fine adjustment (Thermal direct) (PC), (KEY)	-10 step to +10 step
(24)	X axis fine adjustment	-99.5 mm to +99.5 mm
(25)	Ribbon Motor	+15 step to +0 step
(26)	Strip wait status	1: Strip wait status is not sent to the PC. 2: Strip wait status is sent to the PC.
(27)	Threshold manual fine adjustment for the black mark sensor	0.0 V to 4.0 V
(28)	Threshold manual fine adjustment for the feed gap sensor	0.0V to 4.0 V
(29)	Kanji code type (not supported by QQ/QP models.)	TYPE 1: Windows code TYPE 2: Original code
(30)	Euro font code setting	20H to FFH
(31)	Stacker (not supported by QQ/QP models.)	OFF: No stacker ON: with stacker
(32)	Transmission Control Mode	DTR: READY/BUSY (DTR) protocol (DTR/DSR) RTS: READY/BUSY (RTS) protocol (RTS/CTS)
(33)	Reset Selection when the INPUT.PRIME signal is on.	ON: The printer will restore to the initial status. OFF: The printer will not restore the initial status.

**6.2.2 Automatic Diagnostic Printing**

The data from ① to ⑨ on a sample print is printed.

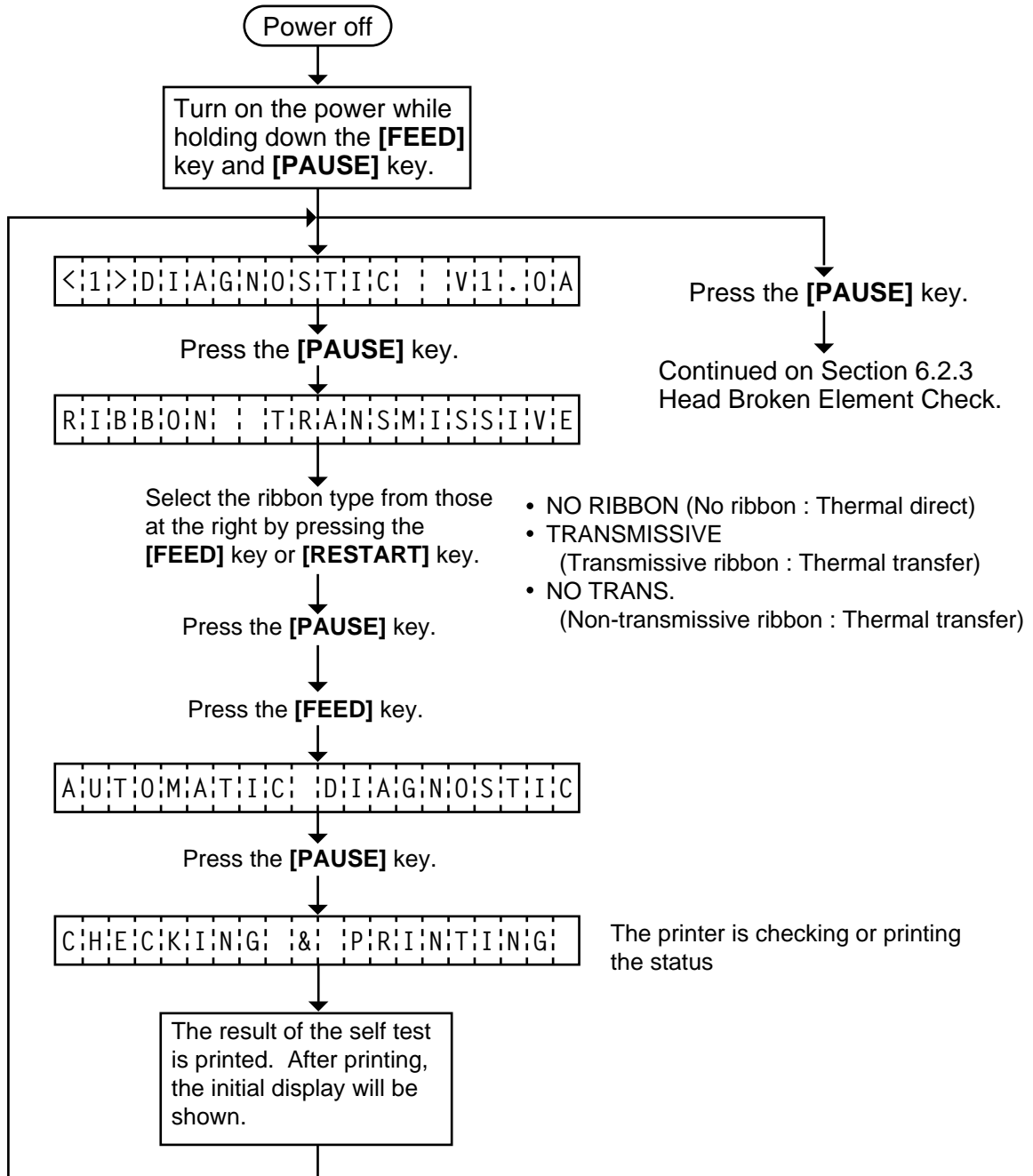

- NOTES:**
1. If the automatic diagnosis printing results in an error, the printer will display the error message and stop printing. The error status can be cleared by the [PAUSE] key, however, the display will return to the initial display "<1> DIAGNOSTIC V1.0A". Printing is not automatically resumed.
  2. Both label and tag paper can be used for printing.

■ Sample Print

[Print Condition]

- Preset count : 1
- Print speed : 127 mm/sec.
- Sensor : No sensor
- Printing method : Thermal transfer
- Supply length : 50 mm
- Issuing mode : Batch printing  
(without rewinder)

①	PROGRAM	V1.0A FMRM0034801:2800
	MASK	V1.0 FMRM0034901:B100
②	KANJI	0000:0000
		0000:0000:0000:0000
③	EEPROM	OK
④	DRAM	1024KB
⑤	CARD	OK
⑥	SENSOR1	00000000,10110011
⑦	SENSOR2	[H]3.1V [A]2.8V [R]3.3V [T]2.4V [RANK]3
⑧	DIP SW	00000000,10001010
⑨	EXP.I/O	OK

Fig. 6-2

① PROGRAM/MASK ROM Check

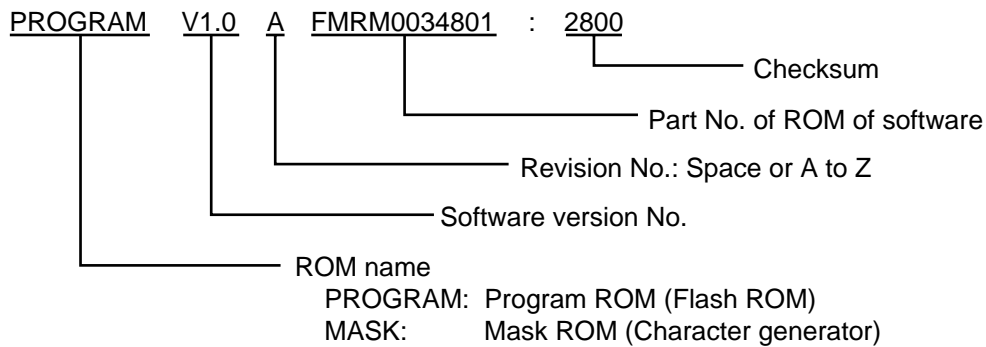

**NOTES:** 1. Software version No., part No. of ROM and checksum vary according to the software version of PROGRAM/MASK ROM.

2. The last two digits of the checksum are usually 0.

② KANJI ROM Check

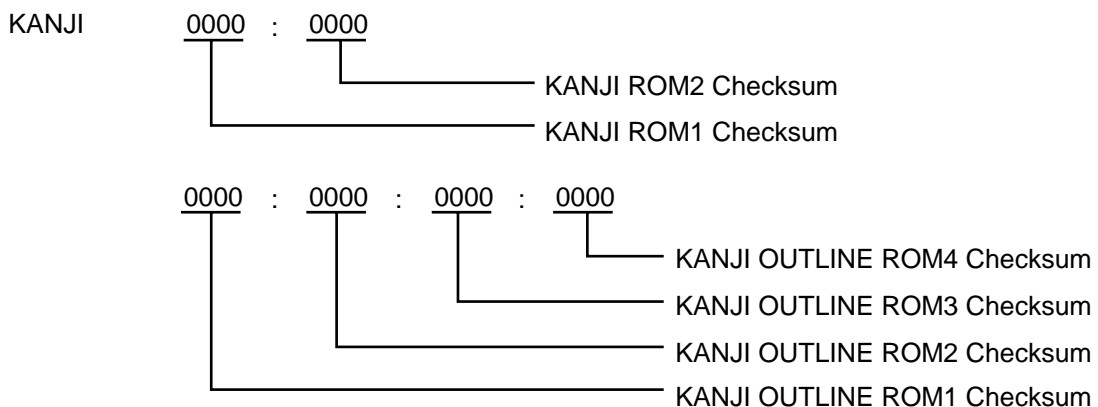

**NOTES:** 1. Checksum varies according to the software version.

2. When the KANJI ROM or KANJI OUTLINE ROM is not installed, the checksum becomes "0000".

3. The last two digits of the checksum are not 0.

③ EEPROM Check

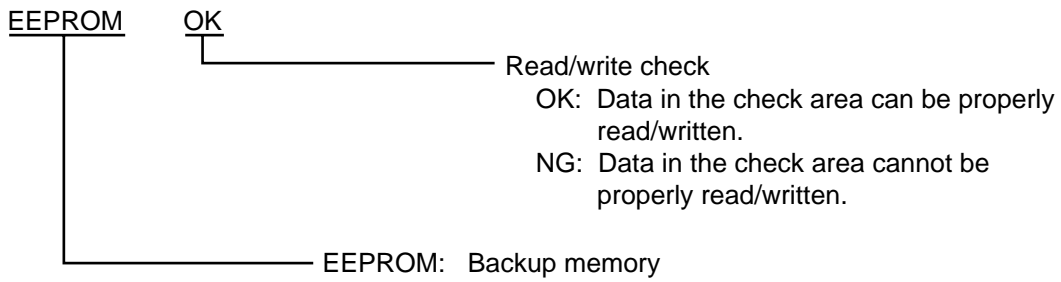

④ DRAM Check

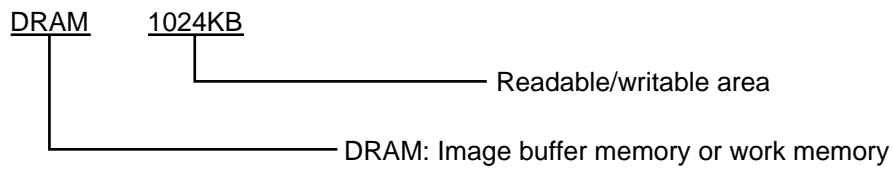

**NOTE:** If an error is detected during DRAM check, the display of readable/writable area will stop when the error occurs.

⑤ Flash Memory Card Check

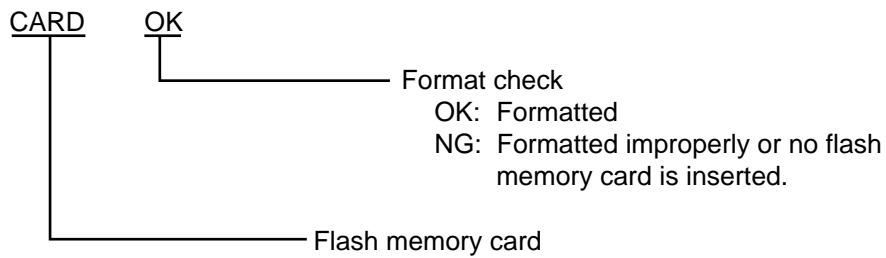

⑥ Sensor 1 Check

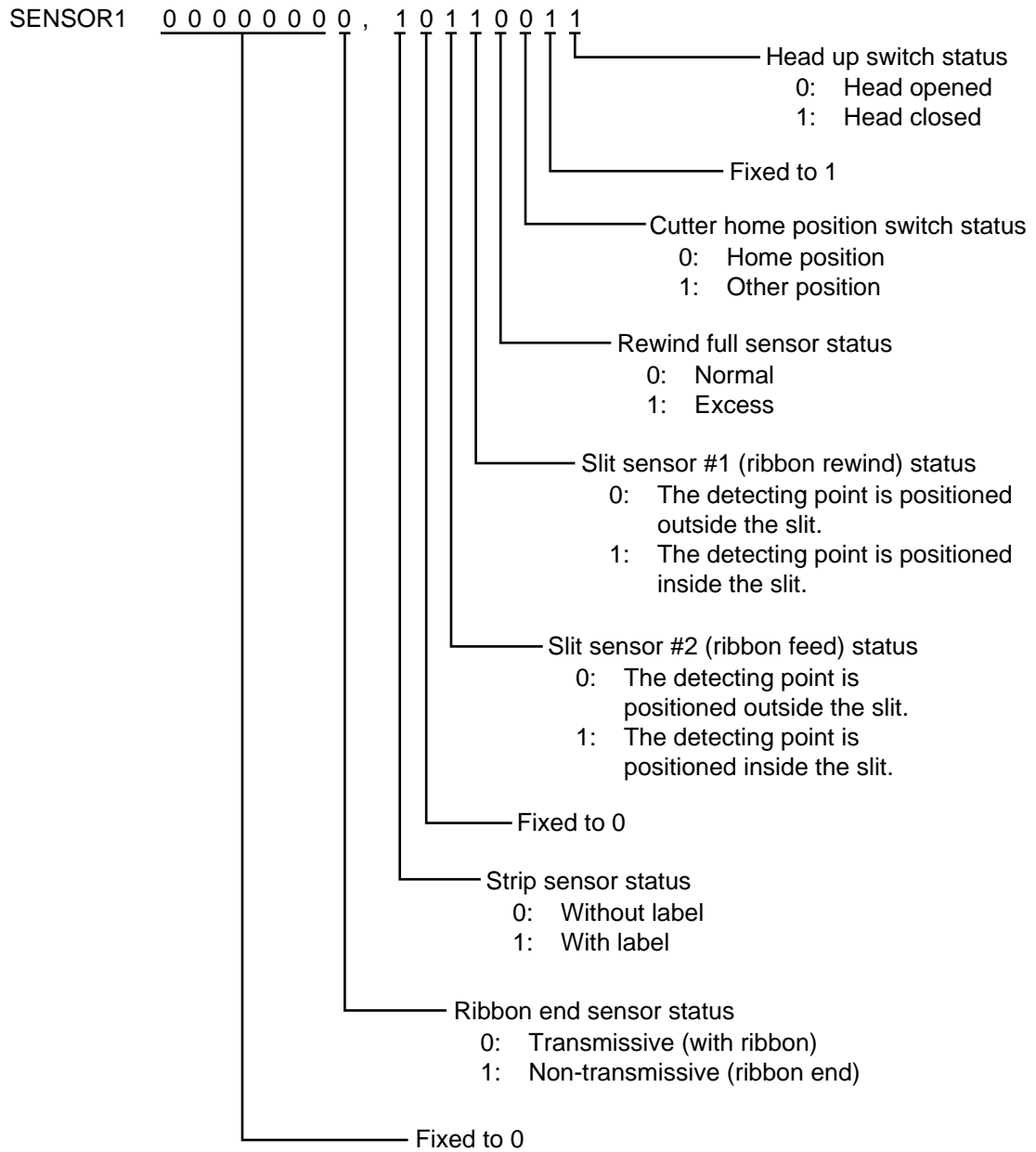

■ Print status content description of each sensor/switch

Sensor/Switch	Print status content description									
Head up switch	Indicates whether the print head is opened or closed.									
Cutter home position switch	Indicates whether the cutter is at the home position or not.									
Rewind full sensor	Indicates whether the media is wound to peak capacity on the built-in take-up spool or not.									
Slit sensor #1 (ribbon rewind) Slit sensor #2 (ribbon feed)	Controls ribbon motor rotation by detecting the slit on the ribbon rewind motor and the ribbon feed motor. Indicates the position of the slit sensor.									
Strip sensor	Indicates the existence of label in strip mode. When no label is detected (0), the subsequent label is issued, when a label is detected (1), the subsequent label will not be issued until the current label is removed.									
Ribbon end sensor	<p>The display of the ribbon end sensor only shows whether the ribbon is transmissive or non-transmissive. The status of the ribbon end detection differs according to the parameter setting. The following table shows the parameter settings in the parameter setting mode.</p> <table border="1" style="margin-left: auto; margin-right: auto;"> <thead> <tr> <th>Type of ribbon \ Ribbon end sensor</th> <th>Transmissive</th> <th>Non-transmissive</th> </tr> </thead> <tbody> <tr> <th>Transmissive</th> <td>With ribbon</td> <td>Ribbon end</td> </tr> <tr> <th>Non-transmissive</th> <td>Ribbon end</td> <td>With ribbon</td> </tr> </tbody> </table>	Type of ribbon \ Ribbon end sensor	Transmissive	Non-transmissive	Transmissive	With ribbon	Ribbon end	Non-transmissive	Ribbon end	With ribbon
Type of ribbon \ Ribbon end sensor	Transmissive	Non-transmissive								
Transmissive	With ribbon	Ribbon end								
Non-transmissive	Ribbon end	With ribbon								

⑦ SENSOR2 Check

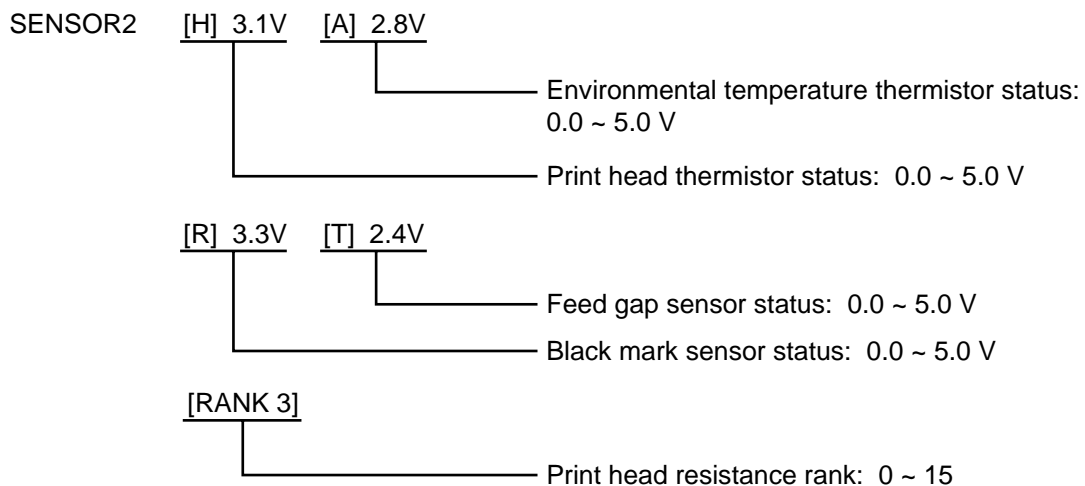



⑧ DIP SW Check

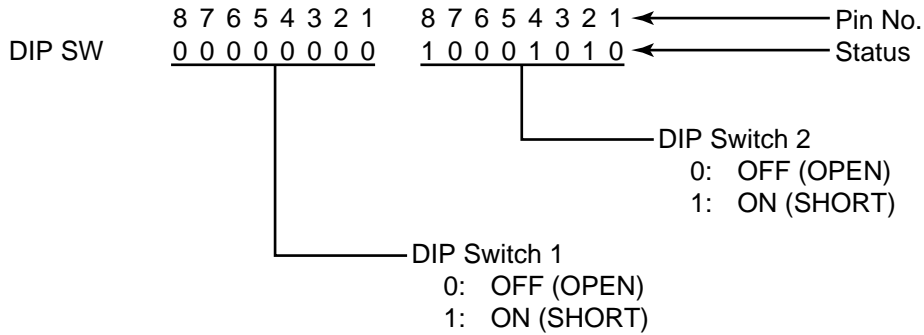

**NOTE:** The DIP switch 1-7 is to be set to 0 (OFF:OPEN) regardless of setting item.

⑨ EXP. I/O Check

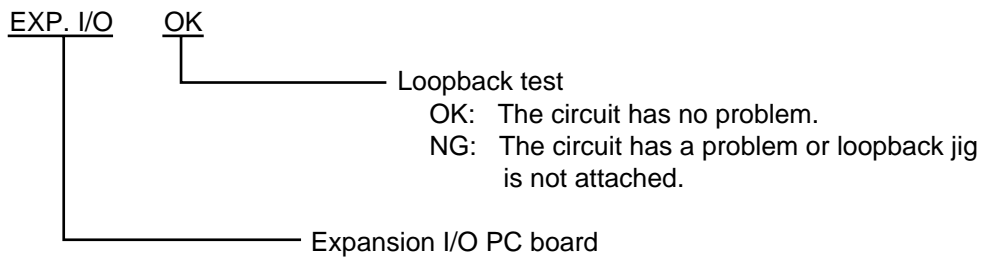

For the loopback test, connect jig as shown below and check HIGH output / HIGH input and LOW output / LOW input.

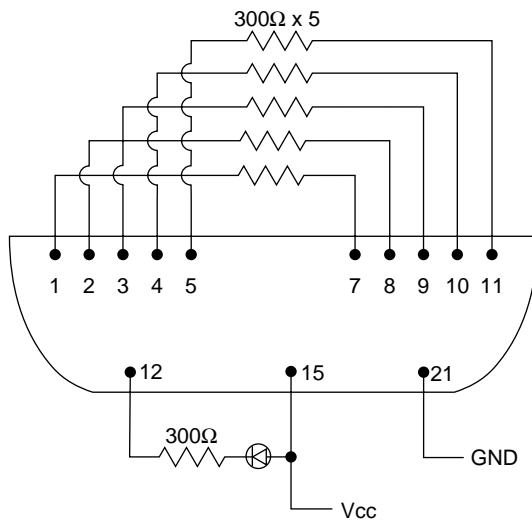

Connector: FCN-781P024-G/P

Fig. 6-3

### 6.2.3 Head Broken Element Check

The printer automatically performs the head broken element check. The result of the head broken element check is indicated in the display.

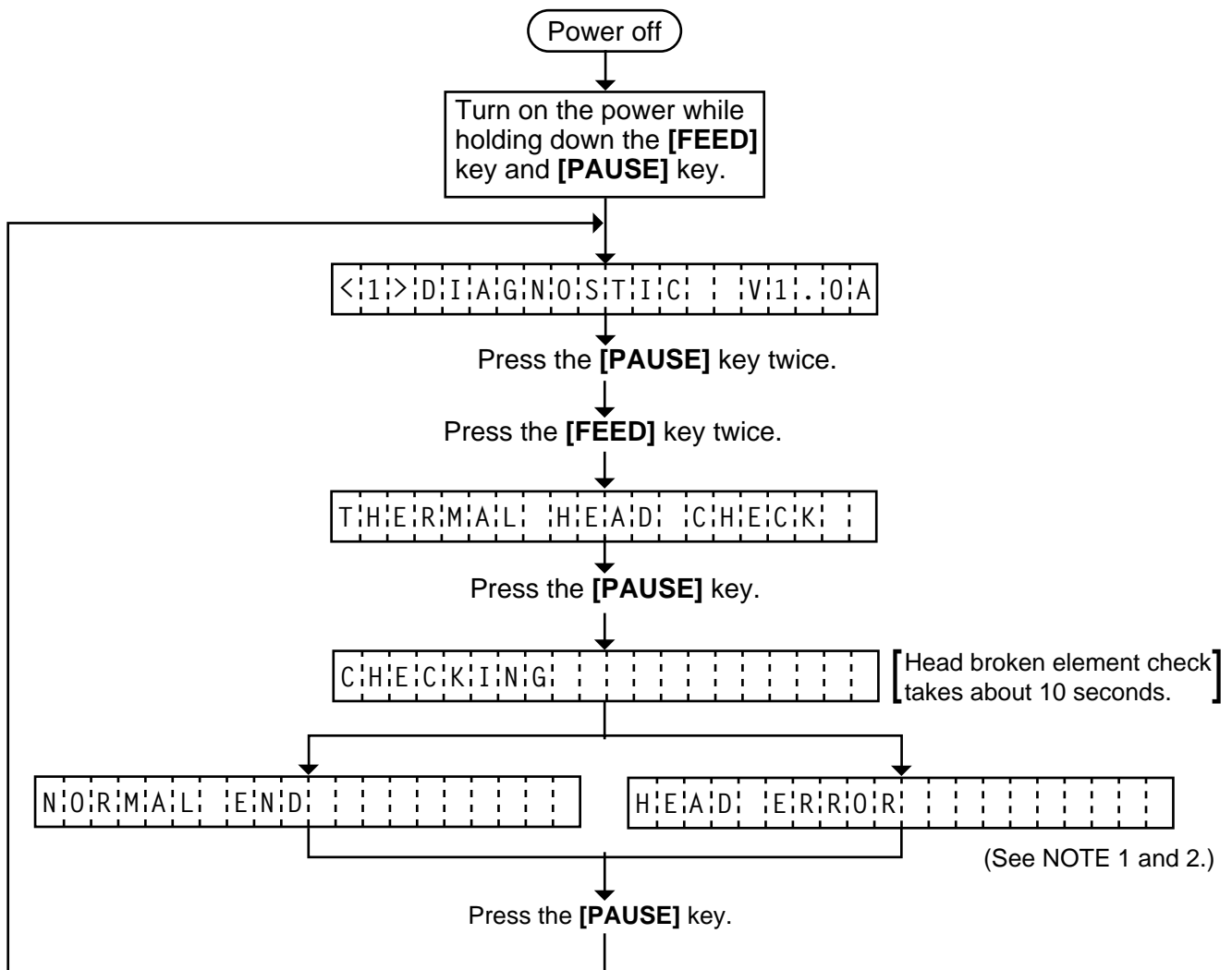

- NOTES:**
1. If the head broken element check results in 'HEAD ERROR', the print head must be replaced after referring to Section 2.6 Replacing the Print Head.
  2. After replacing the print head, clear the maintenance counter as described in Section 6.6.1 and perform a test print in Section 6.4 TEST PRINT MODE.

### 6.3 PARAMETER SETTING MODE

The following items are set in the parameter setting mode. The values set in this mode are printed on the sample print of the maintenance counter. Setting procedure and functions are provided below.

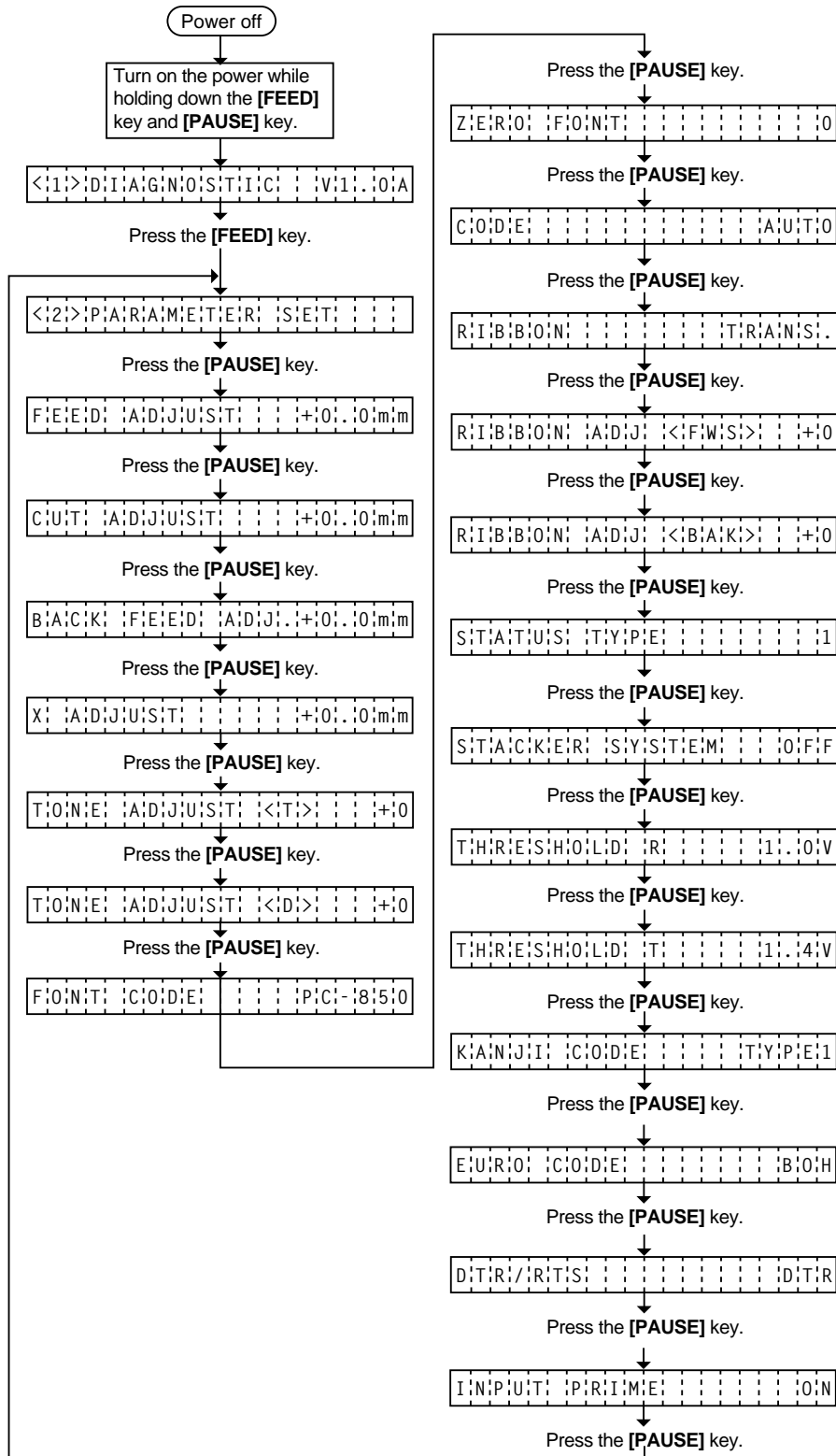

### ■ Parameter Setting Mode Table

Mode Name	Function
FEED ADJUST	Using this parameter the feed length is fine adjusted.
CUT ADJUST	Using this parameter the cut position or strip position is fine adjusted.
BACK FEED ADJ.	Using this parameter the back feed length from the cut/strip position to the home position is fine adjusted.
X ADJUST	This setting is used to finely adjust print position in the X axis.
TONE ADJUST <T> (Thermal transfer printing) TONE ADJUST <D> (Thermal direct printing)	Using this parameter the print tone is fine adjusted. The longer the print pulse width, the darker the print tone becomes. The shorter, the lighter the print tone becomes.
FONT CODE	The character code either PC-850 or PC-8 is selected.
ZERO FONT	The font zero either 0 or ø is selected.
CODE	The command code out of AUTO, ESC/LF/NUL, or { ! } is selected.
RIBBON	Ribbon type either transmissive or non-transmissive is selected.
RIBBON ADJ <FWD> (Ribbon feed motor) RIBBON ADJ <BAK> (Ribbon feed motor)	Using this parameter the torque of the ribbon motors is fine adjusted.
STATUS TYPE	Whether or not the strip wait status (05H) is sent in response to the status request command from the PC is selectable.
STACKER SYSTEM	Use of the Stacker is selected. (not supported by QQ/QP models.)
THRESHOLD R	The threshold of the black mark sensor is manually fine adjusted.
THRESHOLD T	The threshold of the feed gap sensor is manually fine adjusted.
KANJI CODE	Kanji code either Windows code or original code is selected. (not supported by QQ/QP models.)
EURO CODE	EURO code is selected from 20H to FFH.
DTR/RTS	Transmission control mode is selected between DTR and RTS.
INPUT PRIME	Reset ON/OFF when the $\overline{\text{INPUT}} \cdot \text{PRIME}$ signal on is selected.

### 6.3.1 Feed Length Fine Adjustment

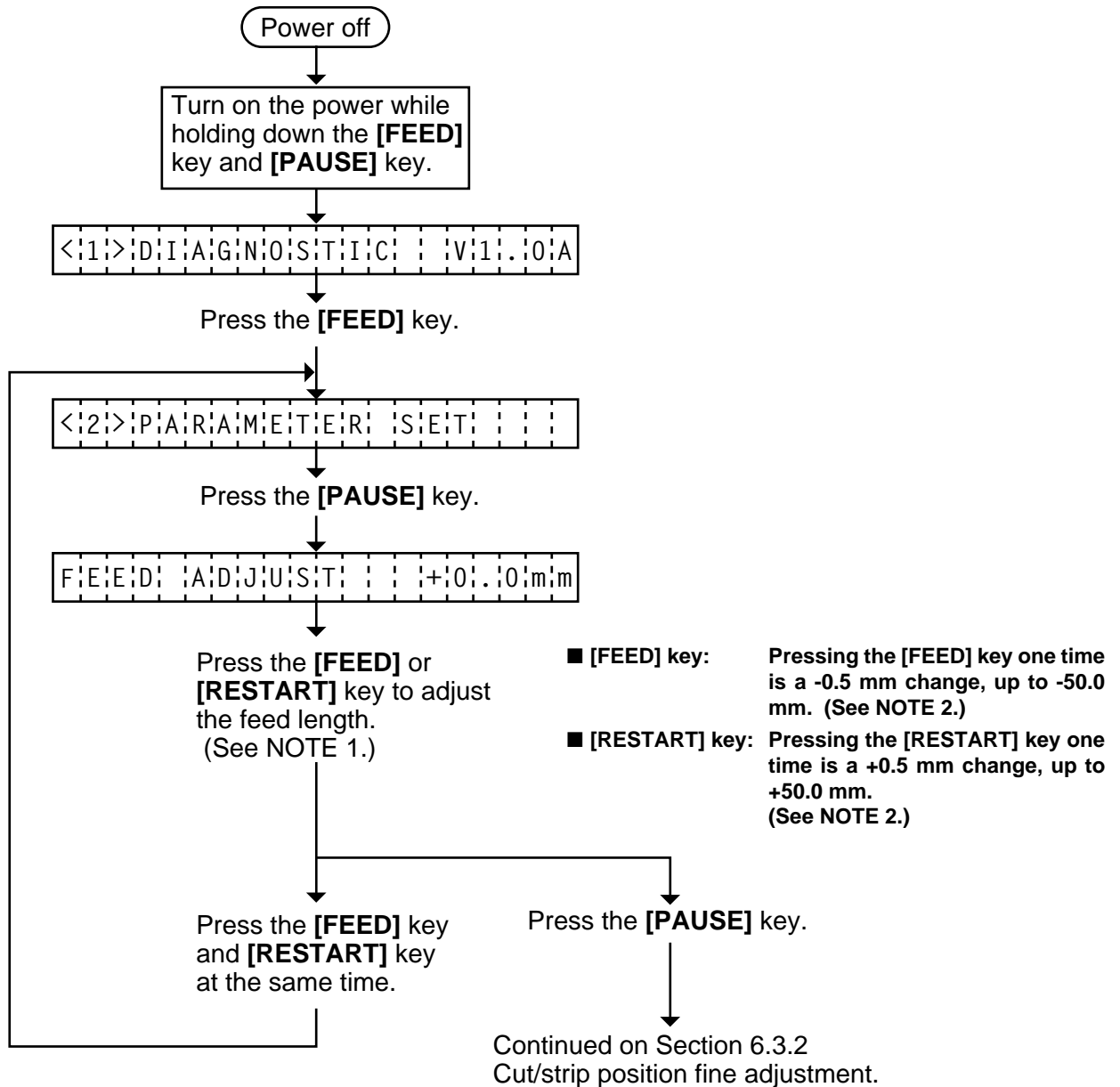

- NOTES:**
1. Holding the **[FEED]** key or **[RESTART]** key down for more than 0.5 seconds enables a fast forward.
  2. Max. fine adjustment  $\pm 50.0$  mm = Key fine adjustment value ( $\pm 50.0$  mm) + PC fine adjustment value ( $\pm 50.0$  mm)  
When the value reaches the maximum, the value remains unchanged even if the subsequent fine adjustment is performed.
  3. A change feed value is stored in memory by pressing the **[PAUSE]** key.

6.3.2 Cut/Strip Position Fine Adjustment

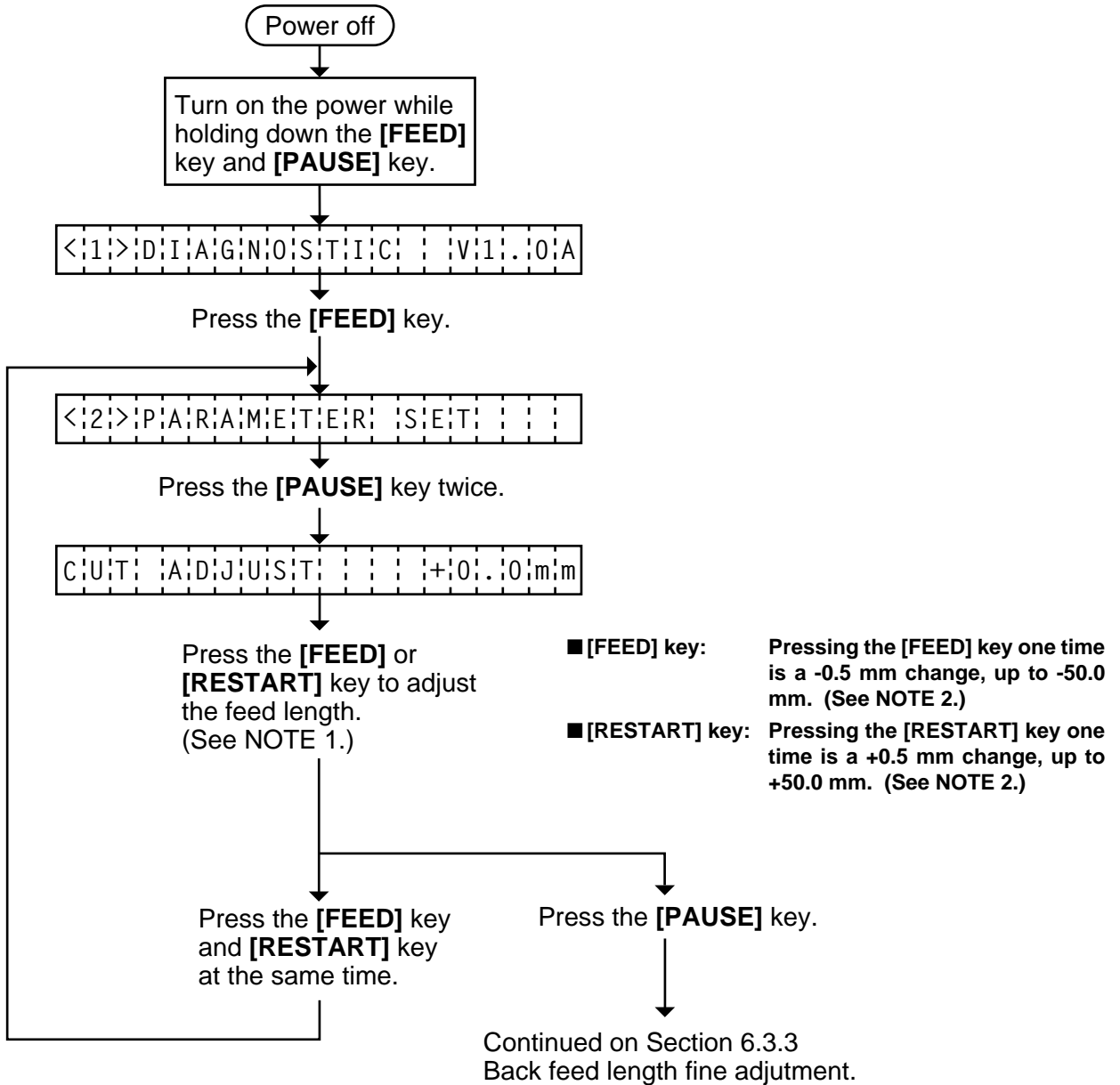

- NOTES:**
1. Holding the **[FEED]** key or **[RESTART]** key down for more than 0.5 seconds enables a fast forward.
  2. Max. fine adjustment  $\pm 50.0$  mm = Key fine adjustment value ( $\pm 50.0$  mm) + PC fine adjustment value ( $\pm 50.0$  mm)  
When the value reaches the maximum, the value remains unchanged even if a subsequent fine adjustment is performed.
  3. A changed cut/strip position value is stored in memory by pressing the **[PAUSE]** key.
  4. When using label with length of less than 38 mm, calculate the cut position fine adjustment value using the expression provided on page 6-19.

### 6.3.3 Back Feed Length Fine Adjustment

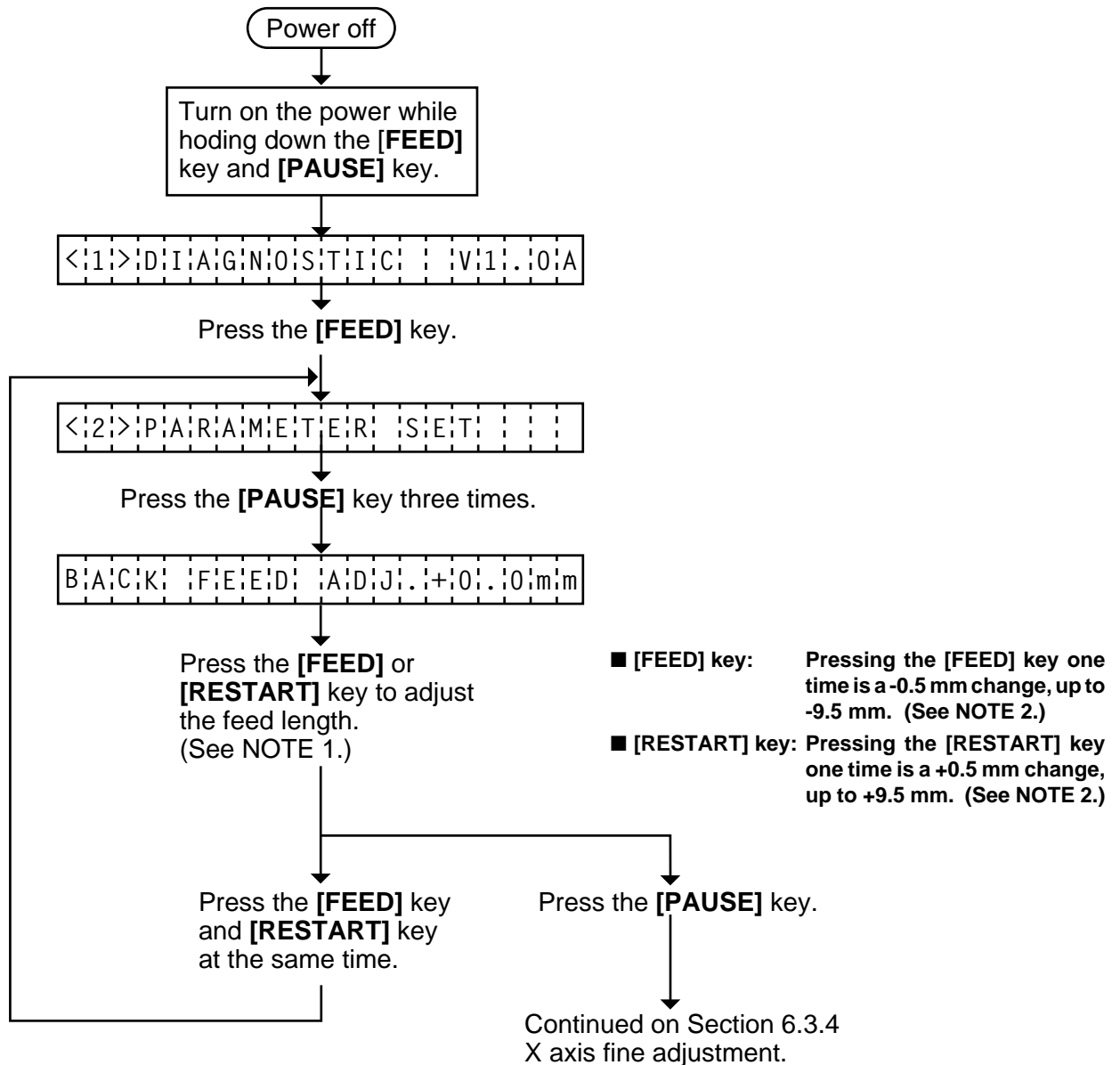

- NOTES:**
1. Holding the [FEED] key or [RESTART] key down for more than 0.5 seconds enables a fast forward.
  2. Max. fine adjustment  $\pm 9.9$  mm = Key fine adjustment value ( $\pm 9.5$  mm) + PC fine adjustment value ( $\pm 9.9$  mm)  
When the value reaches the maximum, the value remains unchanged even if the subsequent fine adjustment is performed.
  3. A changed back feed value is stored in memory by pressing the [PAUSE] key.

■ Feed Length Fine Adjustment Example

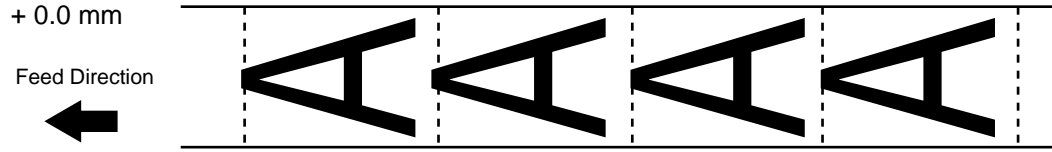

Fig. 6-4

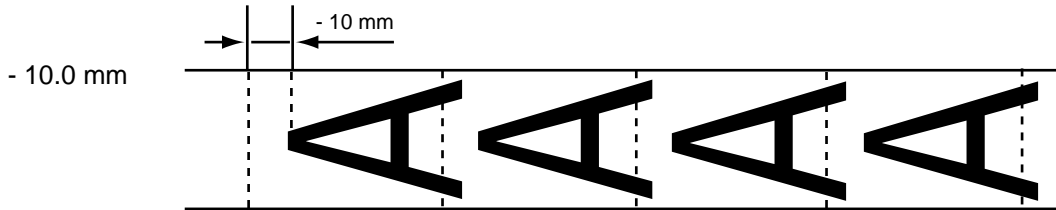

Fig. 6-5

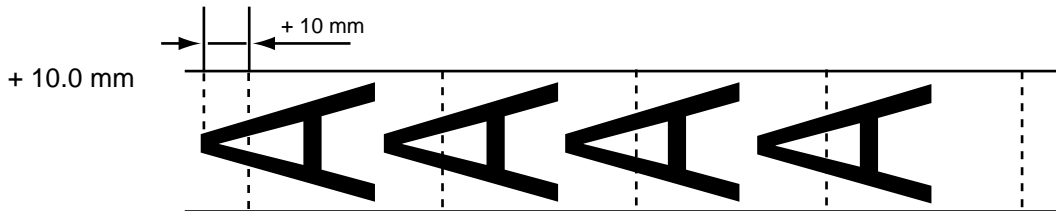

Fig. 6-6

■ Cut Position Fine Adjustment Example

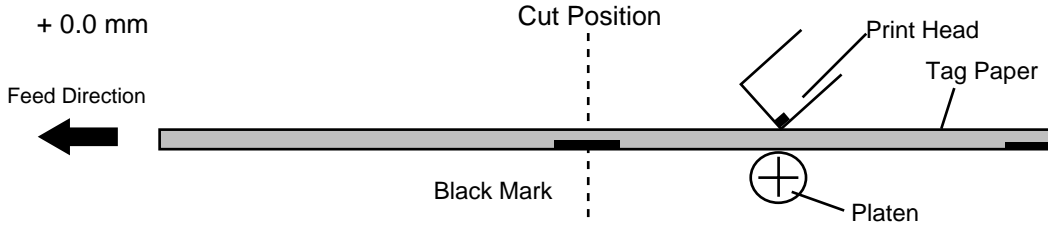

Fig. 6-7

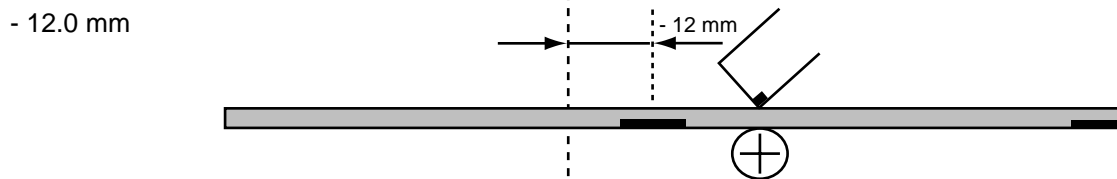

Fig. 6-8

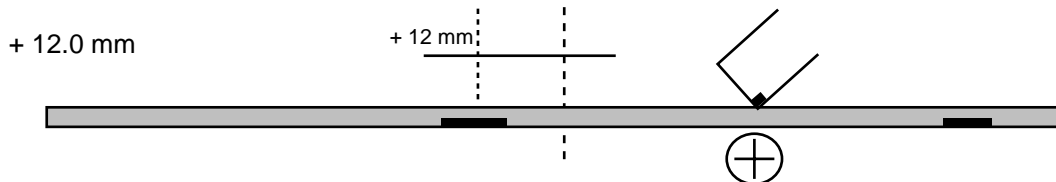

Fig. 6-9



**n When using a label with a length of less than 38 mm :**

**Case 1**

Condition: Issue command [ESC]XS, feed command [ESC]T and eject command [ESC]IB are received.

Label pitch: 38.0 mm or less, with cut, feed gap sensor, cut position fine adjustment value  $\pm 10$  mm or less, and issue mode set to C (cut). When the above conditions are all met, the issue operation in cut issue mode is as follows:

- ① Head lifted → ② Forward feed to the cut position → ③ Head lowered → ④ Cut →
- ⑤ Head lifted → ⑥ Backfed to the home position → ⑦ Head lowered.

**Case 2**

Generally the minimum label length which is available in cut mode is 38.0 mm. When using a label with a length of less than 38 mm, the edge of the label may be caught on the print head during back feed to the print start position after cutting the label gap, causing a improper print start position.

In this case set the cut position fine adjustment value after calculating the value using the following formula so that the unprinted label returns to the correct print start position.

However, use of this method will leave one or two printed label(s) between the print head and the cutter. Feed or print the label(s) to remove them.

(a) Formula for cut position the adjustment value

Cut position fine adjustment value  
 = (the number of labels left between the print head and the cutter) x (span of label)  
 = (32.8 mm/label length) x (span of label)

\* Omit the decimals of the value obtained by dividing 32.8 mm by the label length for one unit.

(example) Span of label : 30.0 mm, Label length : 24.0 mm  
 (32.8 mm/30.0 mm) x 30.0 mm = 1 x 30.0 mm = +30.0 mm

(b) Example

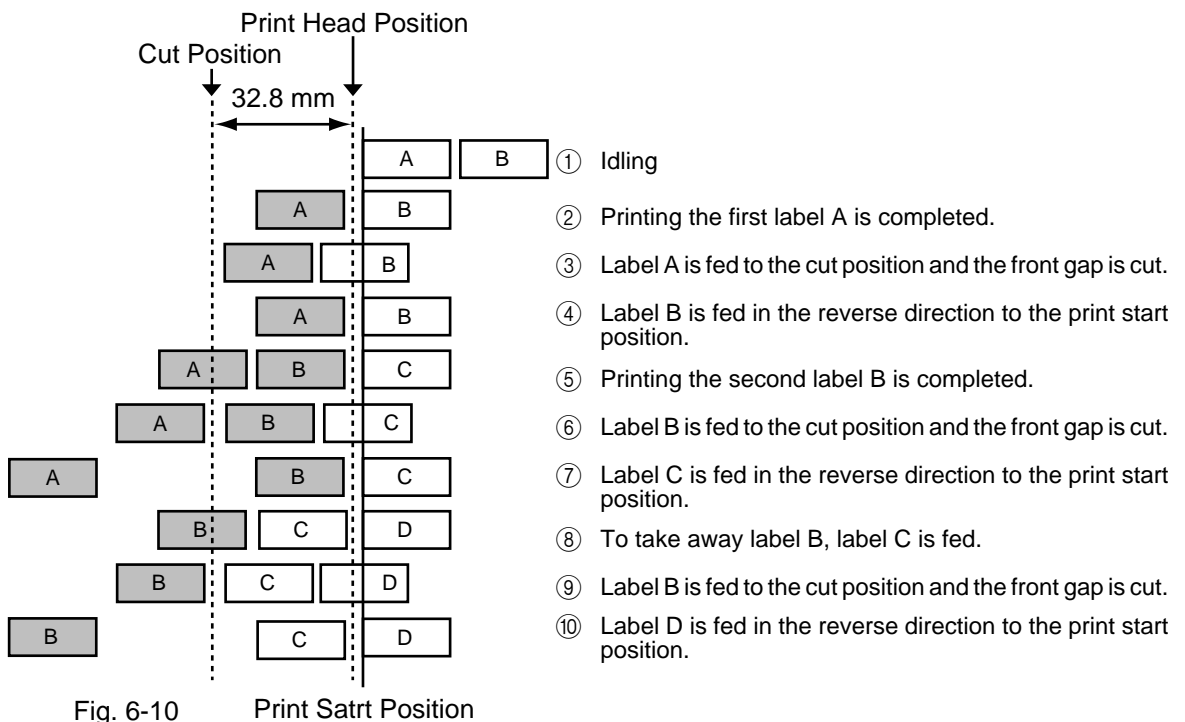

Fig. 6-10

■ Strip Position Fine Adjustment Example

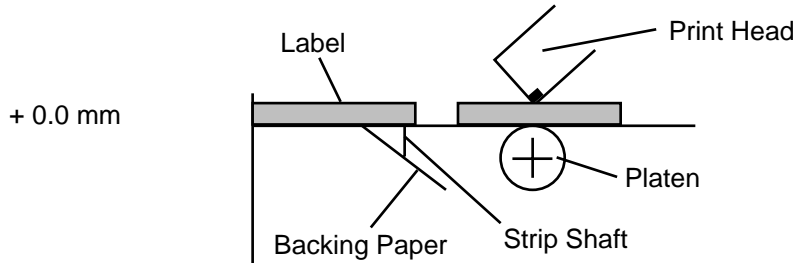

Fig. 6-11

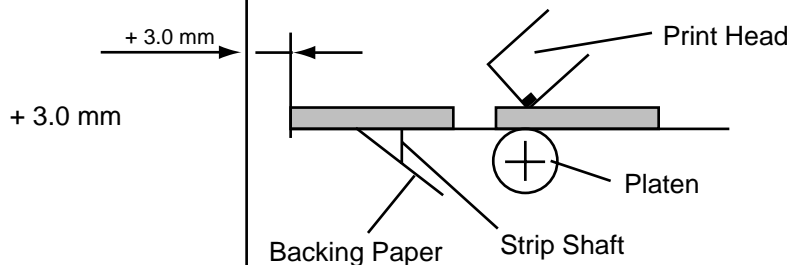

Fig. 6-12

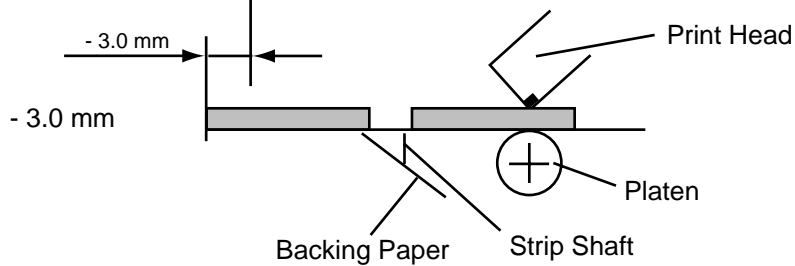

Fig. 6-13

**NOTE:** The print stop position when printing the label in strip mode varies according to label length as the strip mode printing stops so that the edge of the strip shaft is 4 mm from the middle of the gap. This is because the gap length is programmed as 2mm. When the gap length is 5 mm or more, the effective print length should be set to the value obtained by subtracting 2 mm from the label pitch, that is, set the gap length to 2 mm. If the print format hangs over the gap as a result, correct the print start position. If the print stop position is improper, refer to Section 6.3.2 and make a fine adjustment.

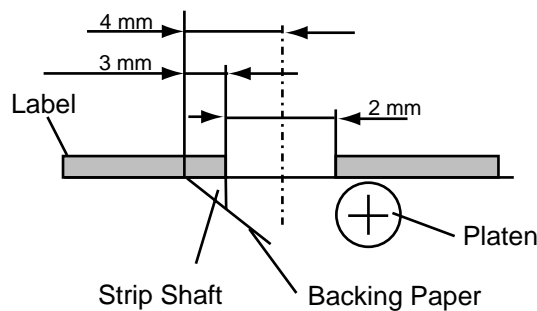

Fig. 6-14

■ Back Feed Length Fine Adjustment Example

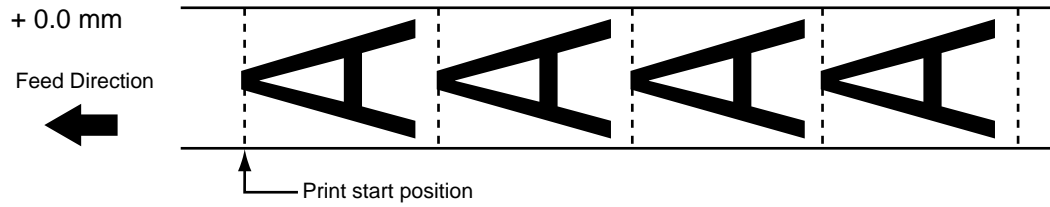

Fig. 6-15

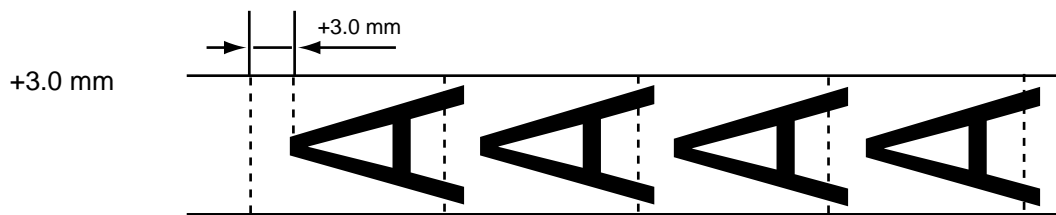

Fig. 6-16

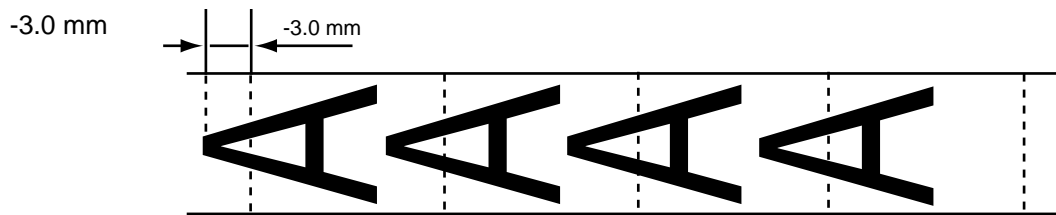
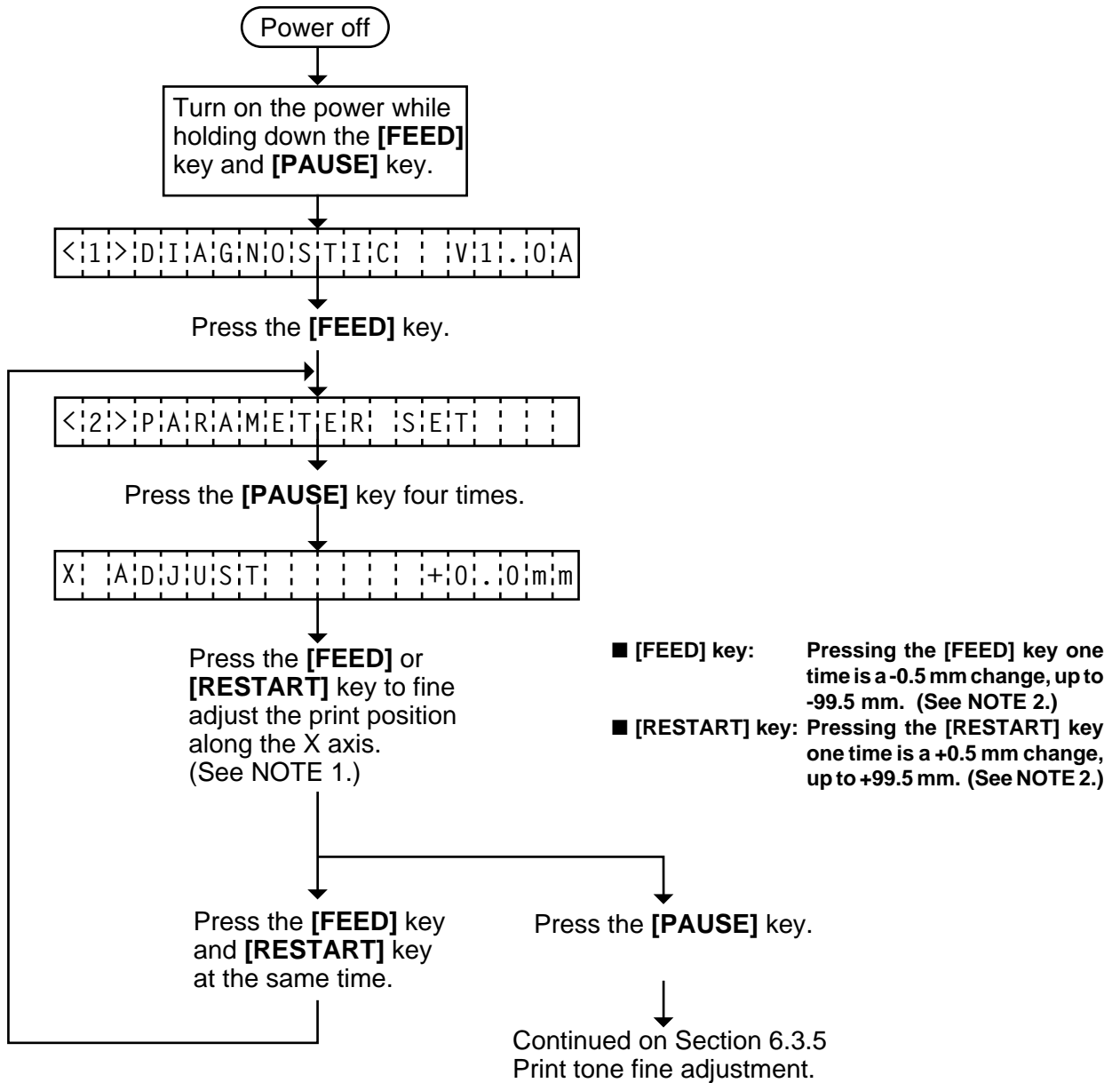

Fig. 6-17

### 6.3.4 X Axis Fine Adjustment



- NOTES:**
1. Holding the **[FEED]** key or **[RESTART]** key down for more than 0.5 seconds enables a fast forward.
  2. Max. fine adjustment  $\pm 99.5$  mm = X axis value  
When the value reaches the maximum, the value remains unchanged even if the subsequent fine adjustment is performed.
  3. A changed X axis is stored in memory by pressing the **[PAUSE]** key.

### ■ X Axis Fine Adjustment Example

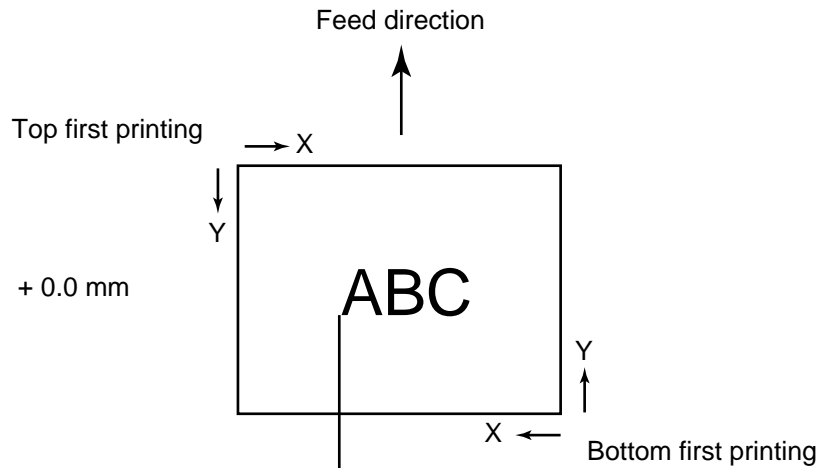

Fig. 6-18

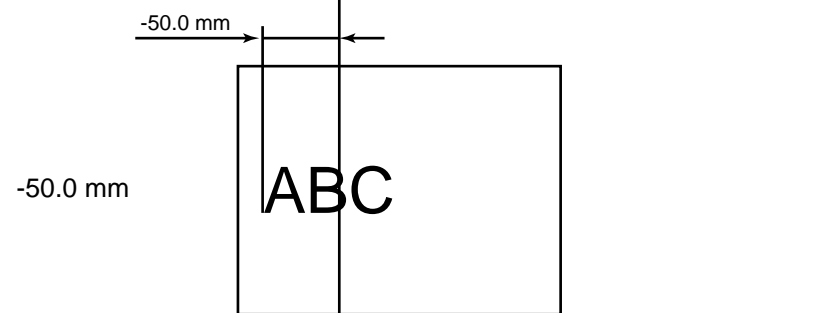

Fig. 6-19

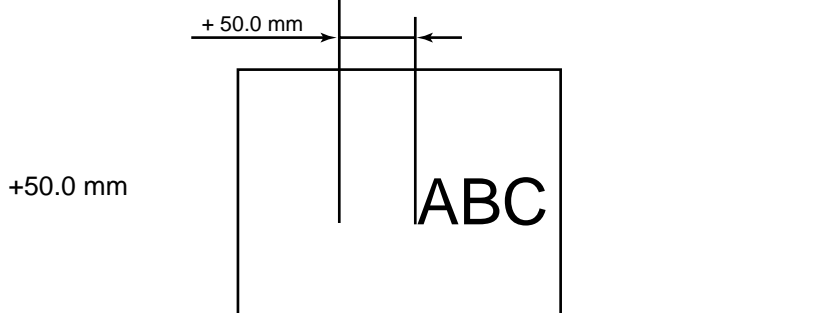
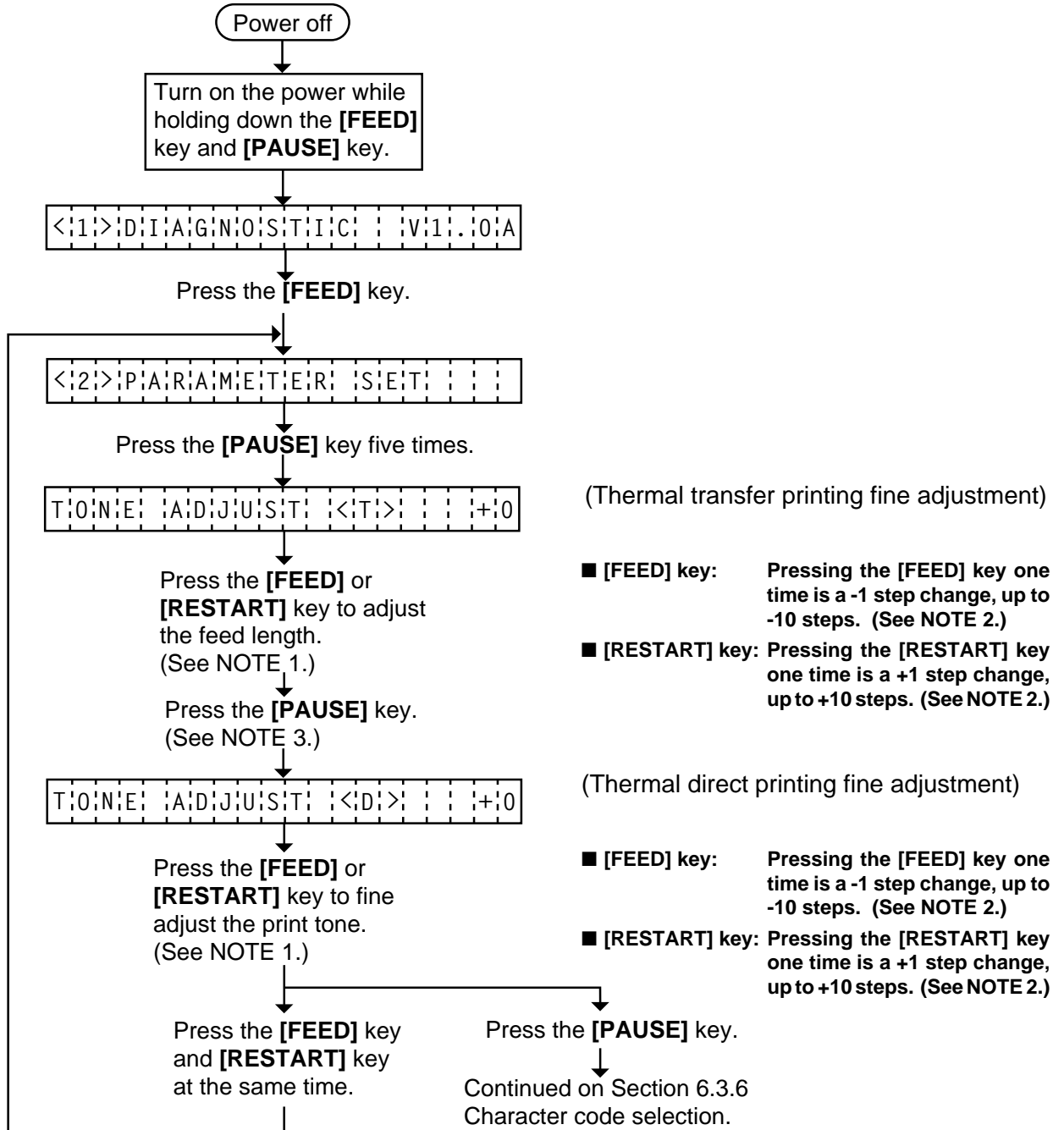

Fig. 6-20

- NOTES:**
1. The X axis fine adjustment is performed to fine adjust the X axis of the drawing in the left or right direction.
  2. Adjust the X axis in the effective print range. (After the value reaches the coordinate "0", the value remains unchanged even if the subsequent fine adjustment is performed in the negative direction.)
  3. X axis fine adjustment cannot be used in self test mode or test printing.

6.3.5 Print Tone Fine Adjustment



- NOTES:**
- 1 Holding the **[FEED]** key or **[RESTART]** key down for more than 0.5 seconds enables a fast forward.
  - 2 A changed print tone value is stored in memory by pressing the **[PAUSE]** key.
  - 3 Fine adjustment value equals to the sum of the values set by the PC command and system mode (key operation) and each max. value is ± 10 step. However, the upper limit of the adjustment value is decided according to the print speed to protect the print head. If the set value exceeds the following upper limit, it is automatically corrected to the proper value.  
 Upper Limit: 3"/sec.: +10 step, 5"/sec.: +5 step, 8"/sec.: +2 step

### 6.3.6 Character Code Selection

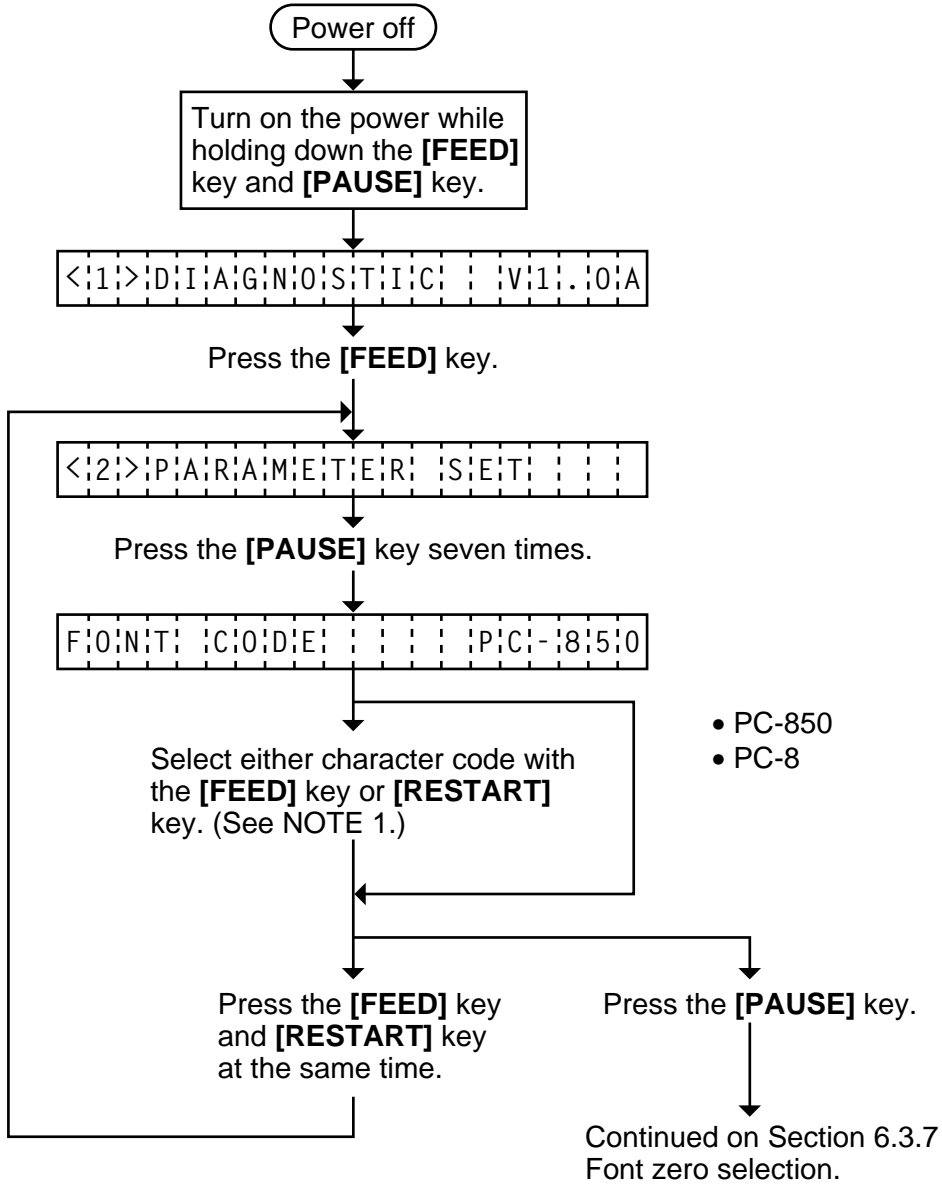

- NOTES:**
1. Holding the **[FEED]** key or **[RESTART]** key down for more than 0.5 seconds enables a fast forward.
  2. A changed font code is stored in memory by pressing the **[PAUSE]** key.

### 6.3.7 Font Zero Selection

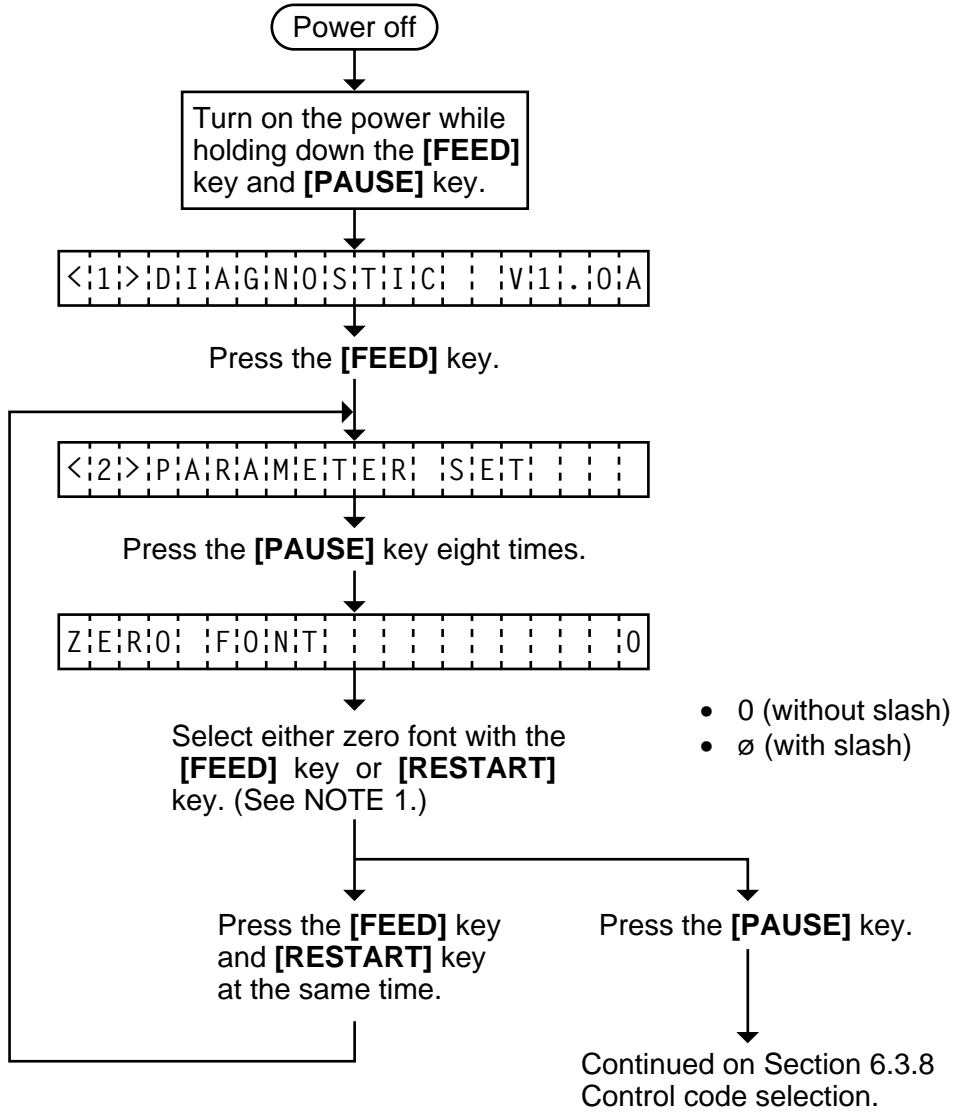

- NOTES:**
1. Holding the **[FEED]** key or **[RESTART]** key down for more than 0.5 seconds enables a fast forward.
  2. A changed zero font is stored in memory by pressing the **[PAUSE]** key.



6.3.8 Control Code Selection

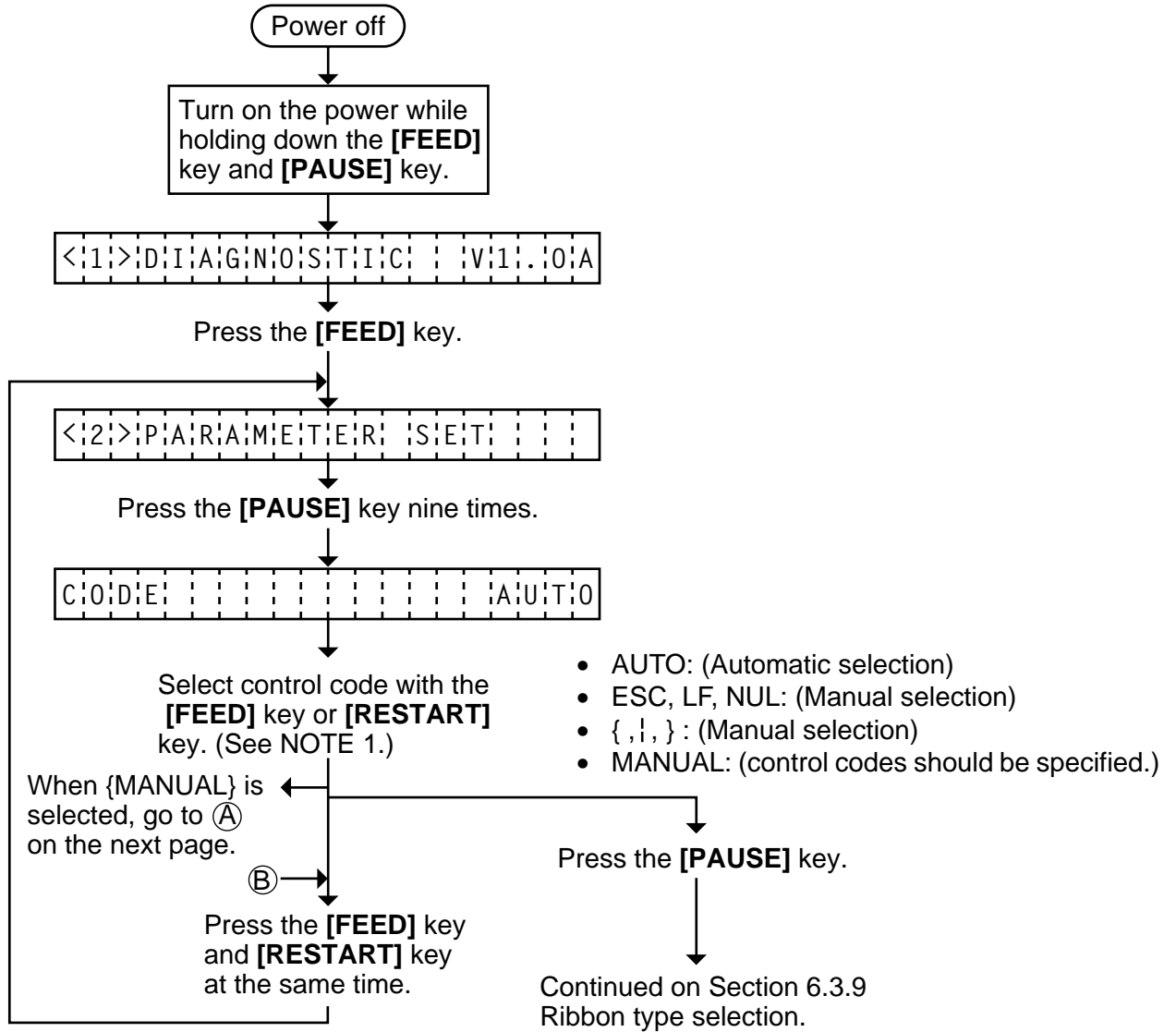

- NOTES:**
1. Holding the [FEED] key or [RESTART] key down for more than 0.5 seconds enables a fast forward.
  2. A changed control code is stored in memory by pressing the [PAUSE] key.
  3. When "AUTO", "ESC, LF, NUL", or "{,!,}" is selected, be sure to select the Non-transmissive ribbon in the ribbon type selection operation.
  4. When "MANUAL" is selected, be sure to specify all the control codes 1 to 3. Failure to do this disables selection of "MANUAL".

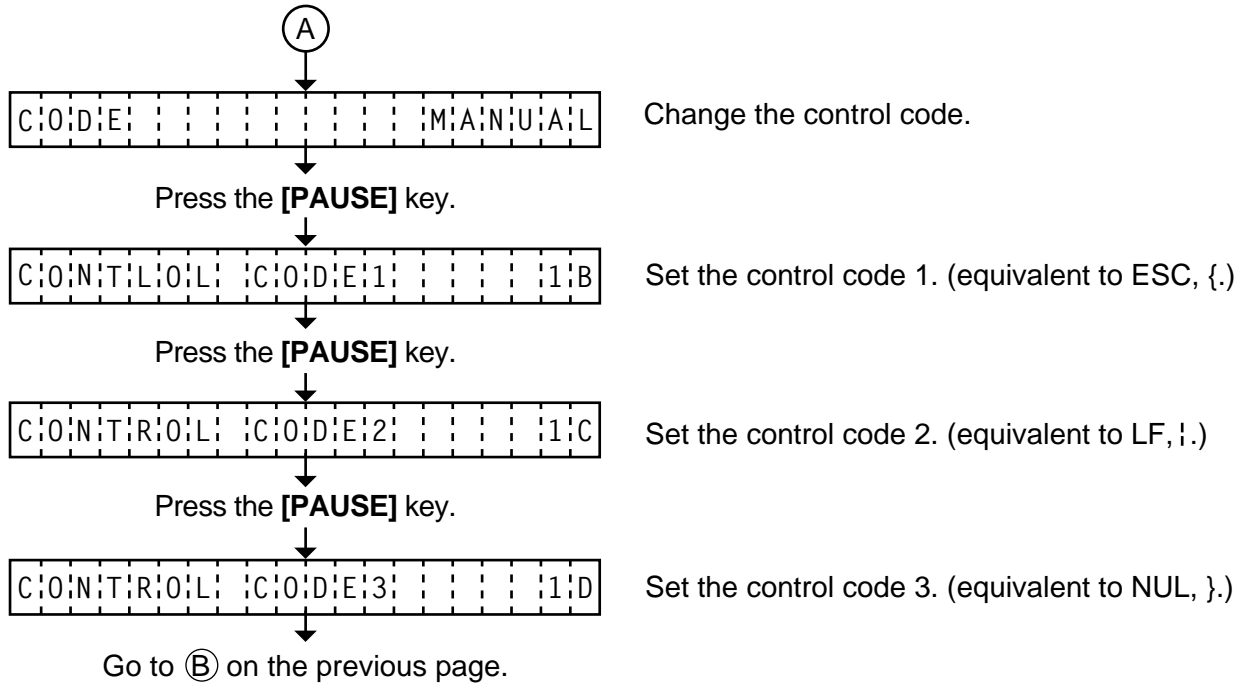

**NOTES:** Refer to the following for the selection of the control codes 1 to 3.

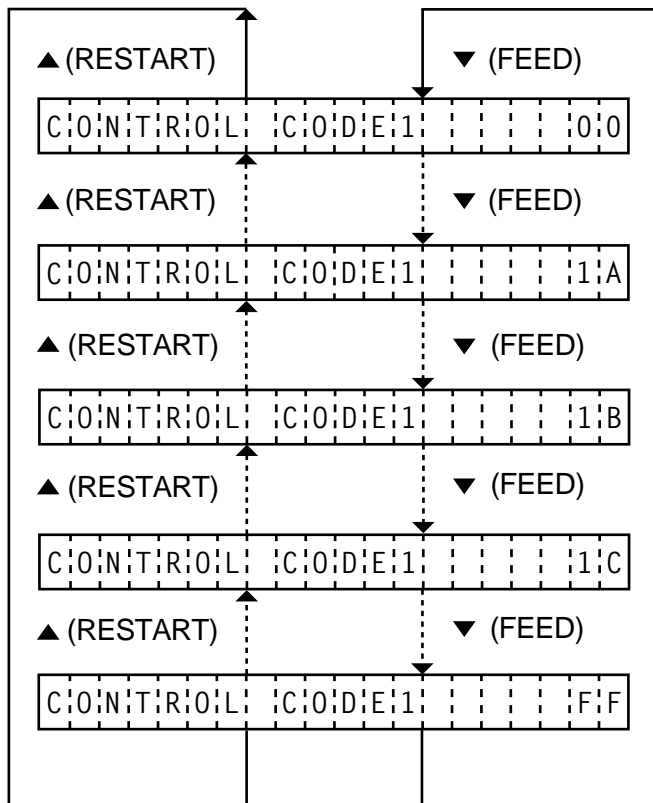

6.3.9 Ribbon Type Selection

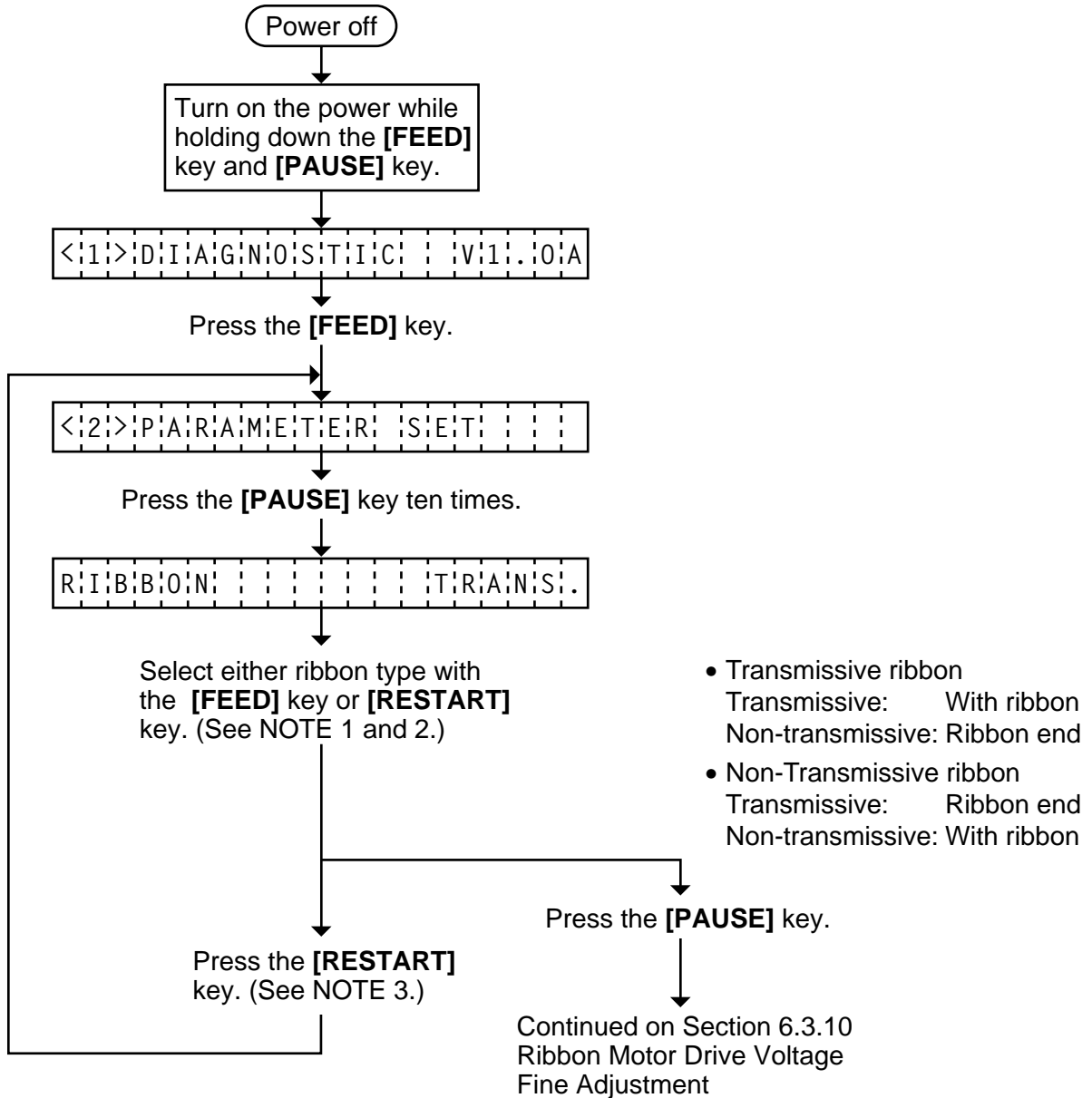

- NOTES:**
1. Holding the **[FEED]** key or **[RESTART]** key down for more than 0.5 seconds enables a fast forward.
  2. Non-transmissive (NON TRANS.) ribbon cannot be used so the ribbon type must be set to transmissive (TRANS.) ribbon.
  3. A changed ribbon type is stored in memory by pressing the **[PAUSE]** key.

6.3.10 Ribbon Motor Drive Voltage Fine Adjustment

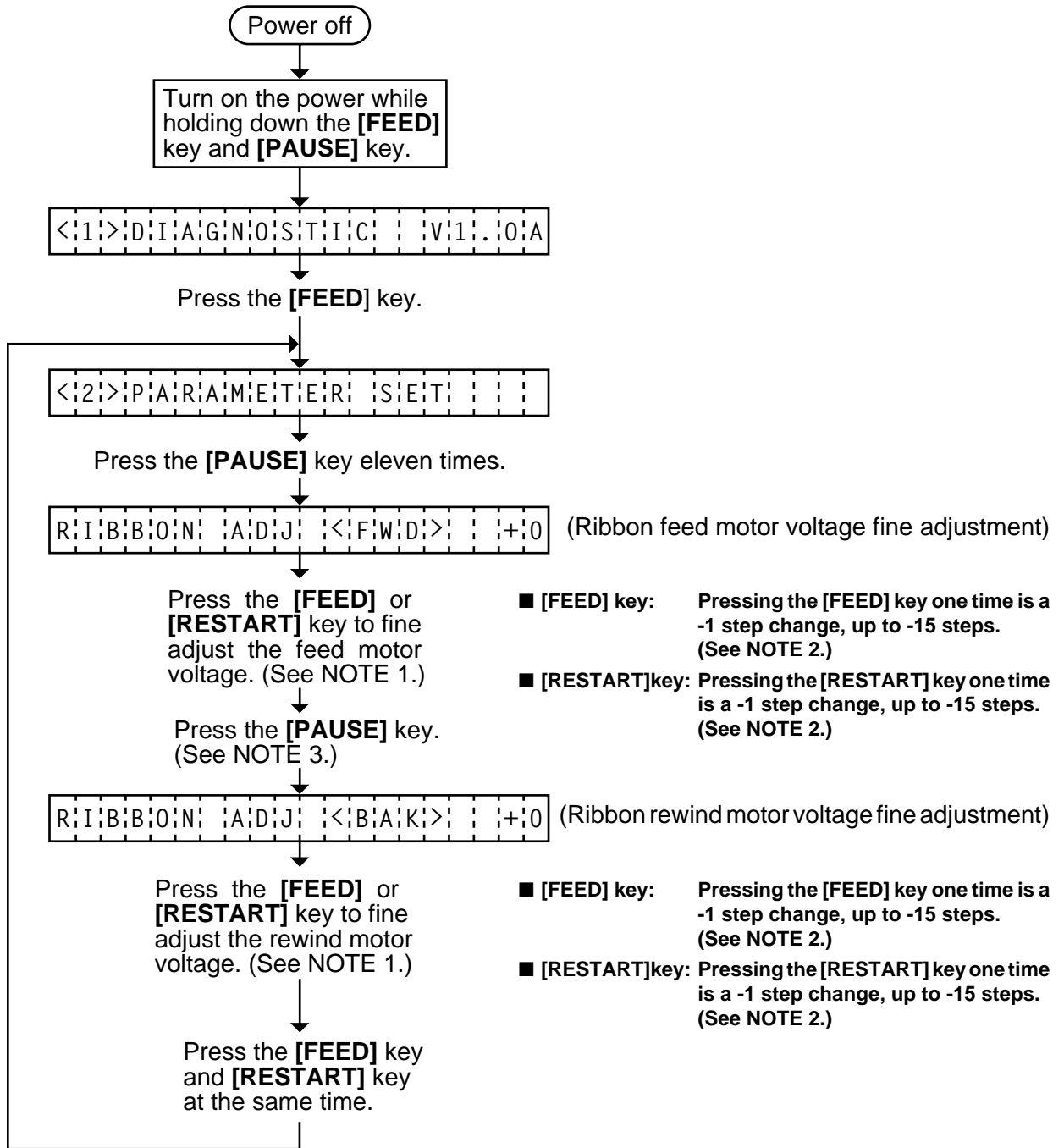

- NOTES:**
1. Holding the [FEED] key or [RESTART] key down for more than 0.5 seconds enables a fast forward.
  2. Max. fine adjustment -15 steps = Key fine adjustment value (-15 steps) + PC fine adjustment value (-15 steps)  
 When the value reaches the maximum, the value remains unchanged even if the subsequent fine adjustment is performed.
  3. A changed motor voltage value is stored in memory by pressing the [PAUSE] key.
  4. One step corresponds to 5% of the standard voltage and up to 75% of the voltage can be decreased.

6.3.11 Strip Wait Status Setting

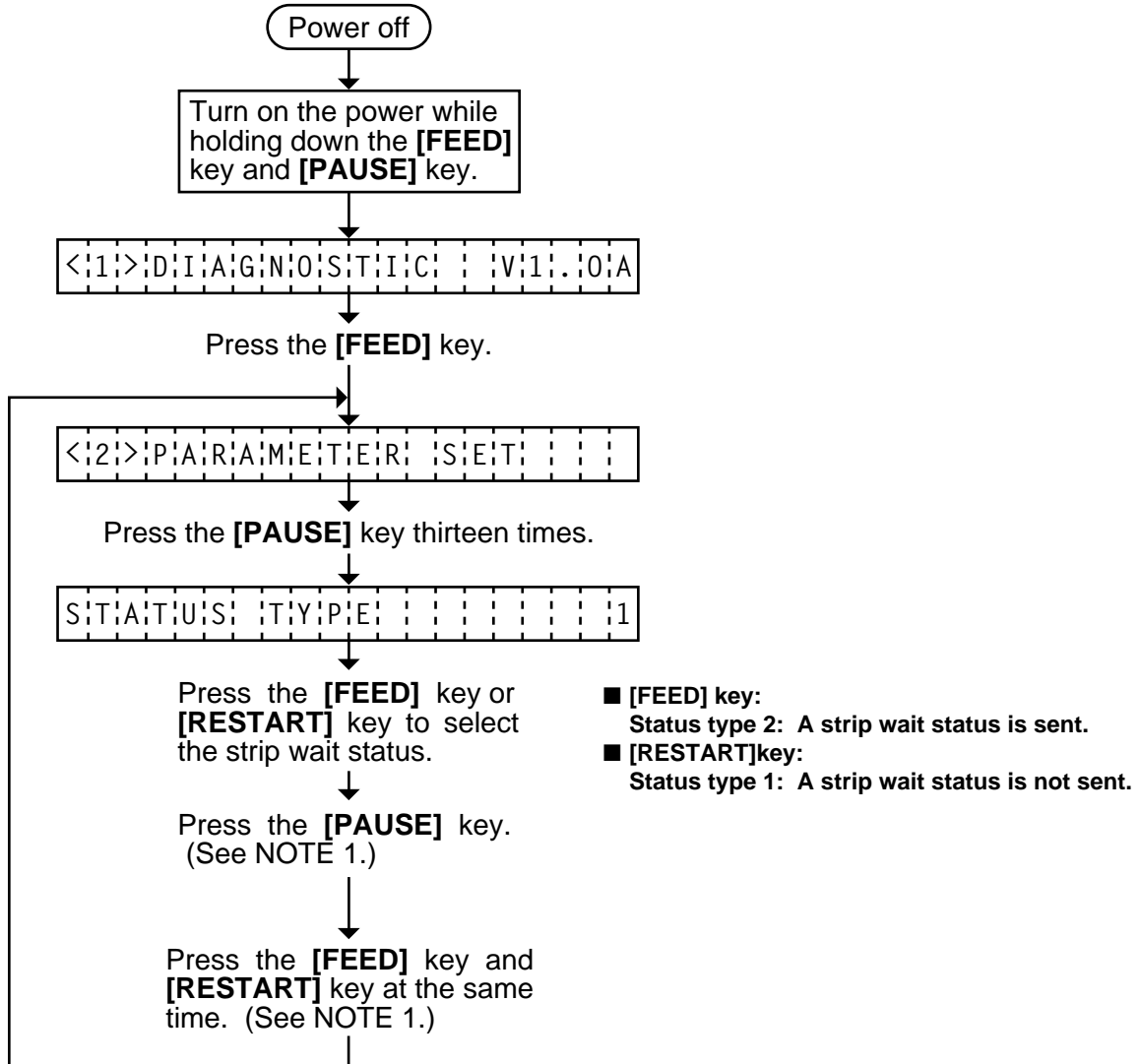

**NOTE:** When the status type 1 is selected, the printer will send (00H) in response to the status request command sent from the PC while a label stays at the strip sensor (when idling, after feeding, or all printing finished).  
 When the status type 2 is selected, the printer will send (05H) in response to the status request command sent from the PC while a label stays at the strip sensor (when idling, after feeding, or all printing finished).  
 If the status request command is sent during printing, the printer will always send (05H) regardless of the setting.

6.3.12 Stacker Selection

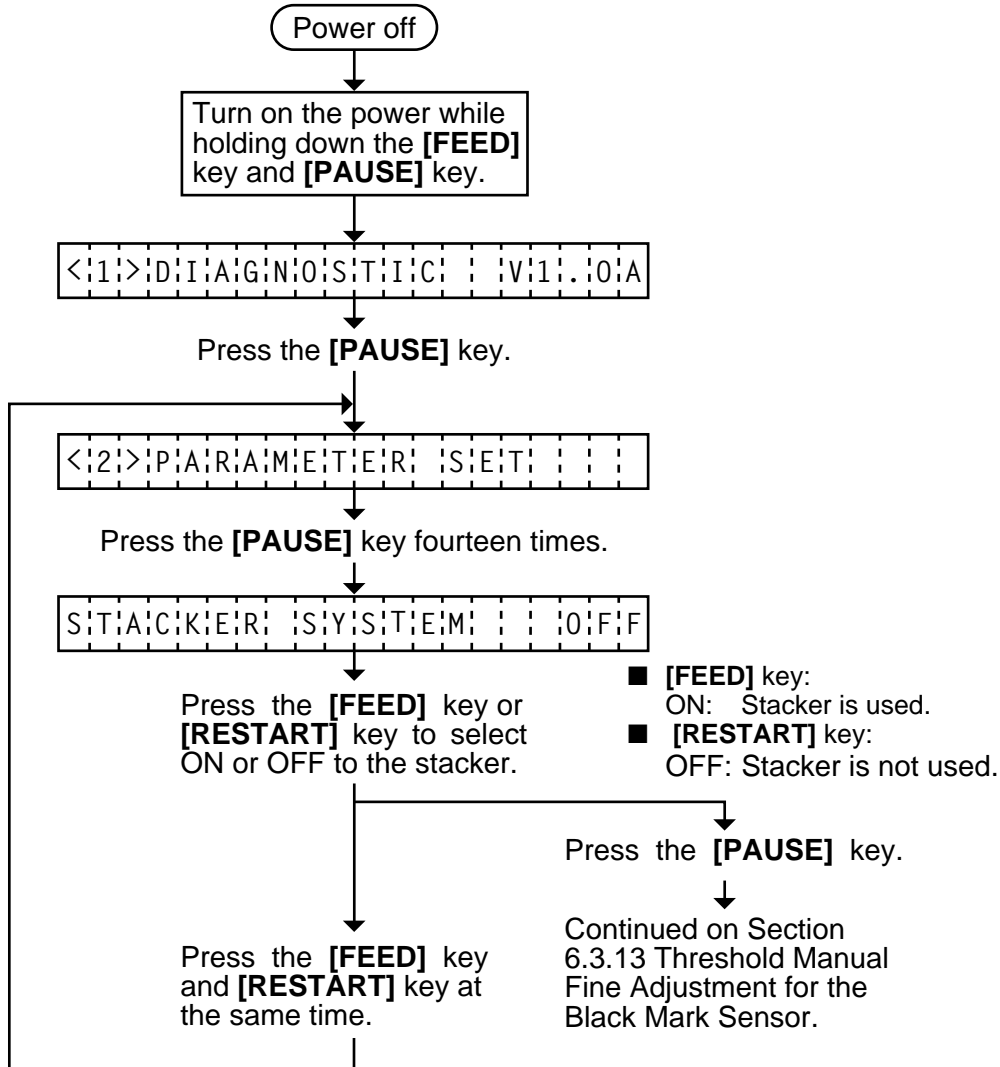

- NOTE:**
1. Holding the [FEED] key or [RESTART] key down for more than 0.5 seconds enables a fast forward.
  2. A changed Stacker selection is stored in memory by pressing the [PAUSE] key.

6.3.13 Threshold Manual Fine Adjustment for the Black Mark Sensor

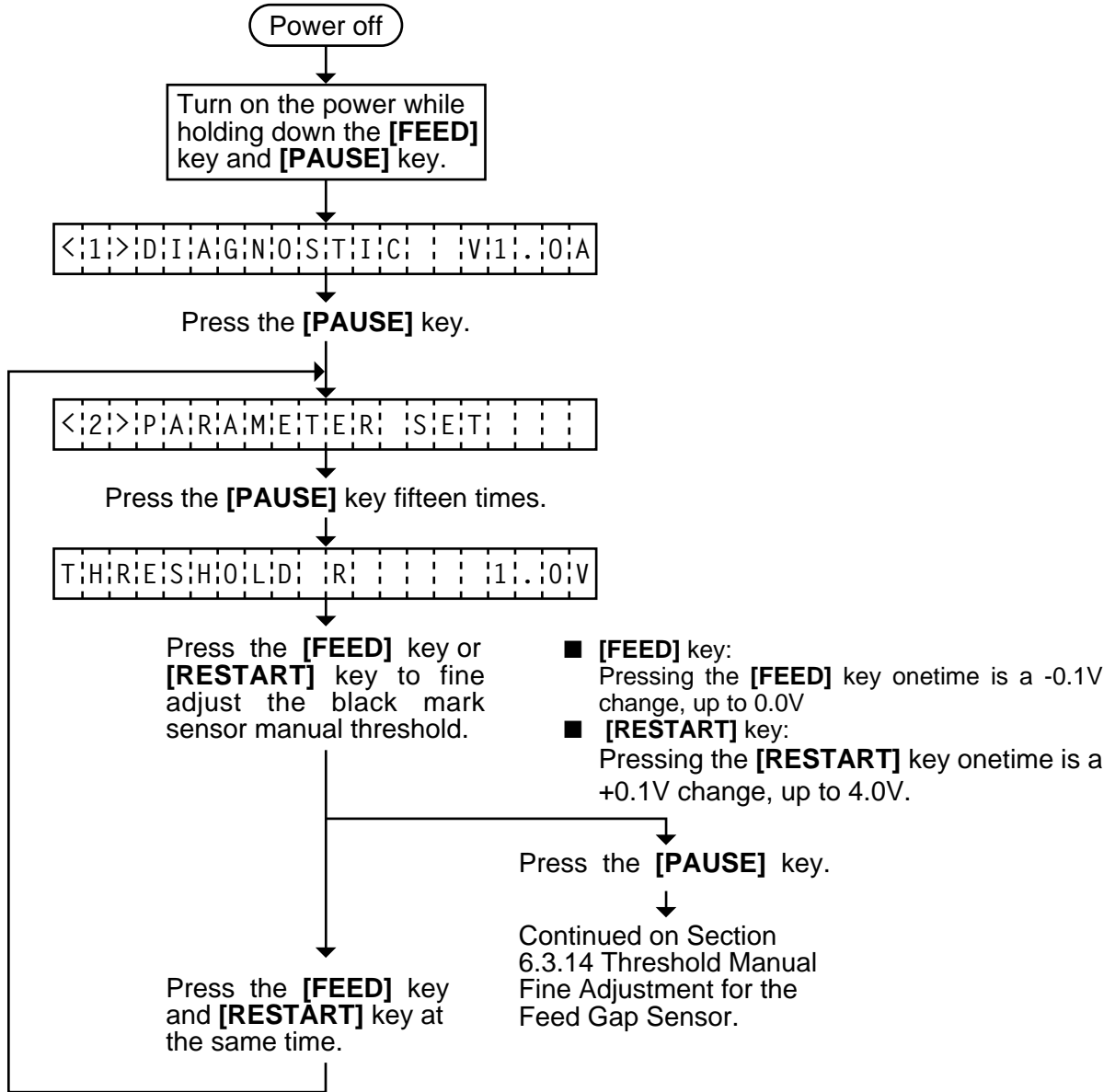

- NOTE:**
1. Holding the [FEED] key or [RESTART] key down for more than 0.5 seconds enables a fast forward.
  2. A changed threshold fine adjustment value is stored in memory by pressing the [PAUSE] key.
  3. The above operations do not require any more threshold setting.

6.3.14 Threshold Manual Fine Adjustment for the Feed Gap Sensor

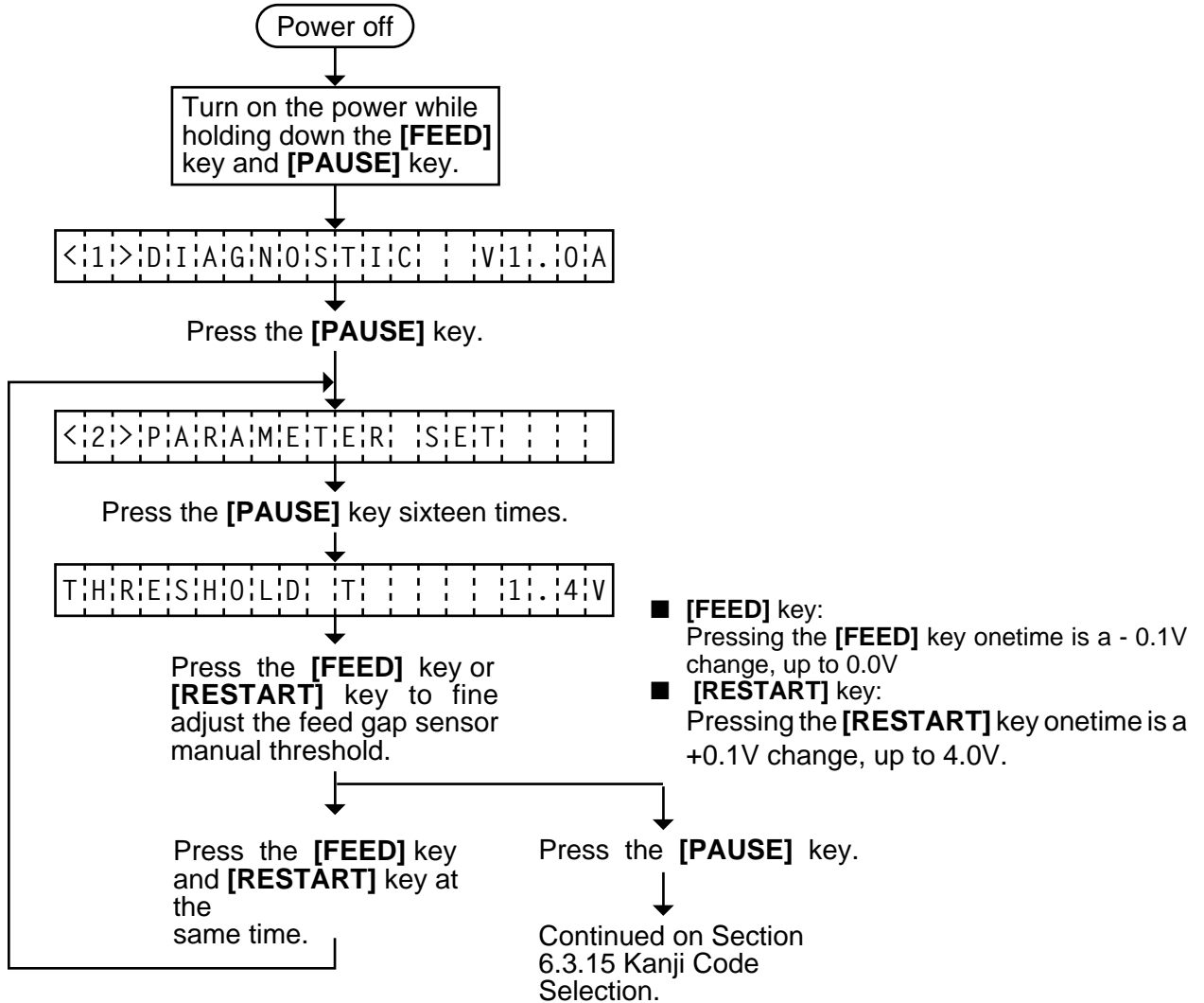

- NOTES:**
1. Holding the **[FEED]** key or **[RESTART]** key down for more than 0.5 seconds enables a fast forward.
  2. A changed threshold fine adjustment value is stored in memory by pressing the **[PAUSE]** key.
  3. The above operations do not require any more threshold setting.



## ■ How To Calculate Theshold Fine Adjustment Value

If the following cases occurred, threshold value for the paper sensors should be fine adjusted after referring to the next page.

### Case 1:

When using tag paper, the black mark and the print area are distinguished from each other by the 1.5V or more difference of sensor output voltage. If a low-sensitive sensor is installed in the printer, it may not detect 1.5V or more difference between the black mark and the print area. This may cause the printer to feed over one and a half tags, and then stop with "PAPER JAM" displayed.

### Case 2:

The presence and lack of label are distinguished from each other by the reflective sensor voltage. When the voltage is more than 1.5V, it is regarded as the presence of paper. And less than 1.5V is regarded as the paper end. If a low-sensitive-sensor is used, 1.5V or more may not be detected at the backing paper since the reflectance of backing paper is low. In such case, more than 5mm-long gap is regarded as the no paper. And trying to print or feed the label when the sensor stops at the gap results in a NO PAPER error. This problem tends to occur when using labels with thin backing paper.

### Case 3:

If the reflective sensor's output voltage when detecting no paper is 1.5V or more, the sensor does not recognize the actual paper end during printing. Accordingly, the printer continues to print despite of the paper end. This problem may occur on printers of which the resistors on the CPU PCB have been changed according to the Technical Information #SVM7A1010/1 (issued on April 16, 1997).

### Case 4:

When using perforated fanfold labels, the transmissive sensor mistakes the perforation on the gap for a print area, resulting in a PAPER JAM error.

### Case 5:

When using such a particular label stock that a black mark is printed on every two or three gaps, the sensor detects three different voltages at the label, unmarked gap and black mark, respectively. The sensor cannot distinguish the unmarked gap from the black mark, so the printer stops with displaying "PAPER JAM".

**NOTE:** The following operation cannot be performed unless the sensor type is changed by the issue command or feed command.

(1) Using the sensor adjustment in Diag. mode, measure the sensor voltage at the following four points.

Label: Print area Backing paper

Tag paper: Print area Black mark

Example:

[ R E F L E C T I V E ]	2.8 V
[ T R A N S M I S S I V E ]	4.1 V

(2) Using the following formula, calculate the threshold from the measured voltage:

**When using labels (transmissive sensor):**

Threshold = (Max. voltage at the backing paper) - (Voltage at the print area) - 0.7V

e.g.) 2.0V = 4.2V - 1.5V - 0.7V

**When using perforated labels (transmissive sensor):**

$$\text{Threshold} = \frac{\text{(A) (Max. voltage at the backing paper)} + \text{(B) (Min. voltage at the backing paper)}}{2} - \frac{\text{(A) (Max. voltage at the backing paper)}}{2}$$

e.g.) 2.2V = 4.4V - (2.8V/2) - (1.6V/2)

**When using labels with black marks (reflective sensor):**

$$\text{Threshold} = \frac{\text{(C) (Min. voltage at the print area)} - \text{(D) (Min. voltage at the black mark)}}{2}$$

e.g.) 0.4V = (1.5V - 0.7V)/2

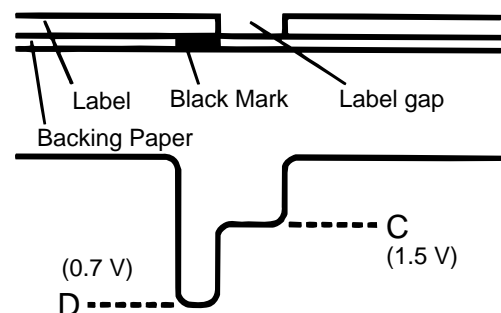
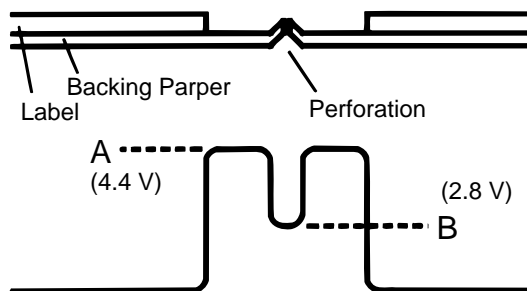

6.3.15 Kanji Code Selection

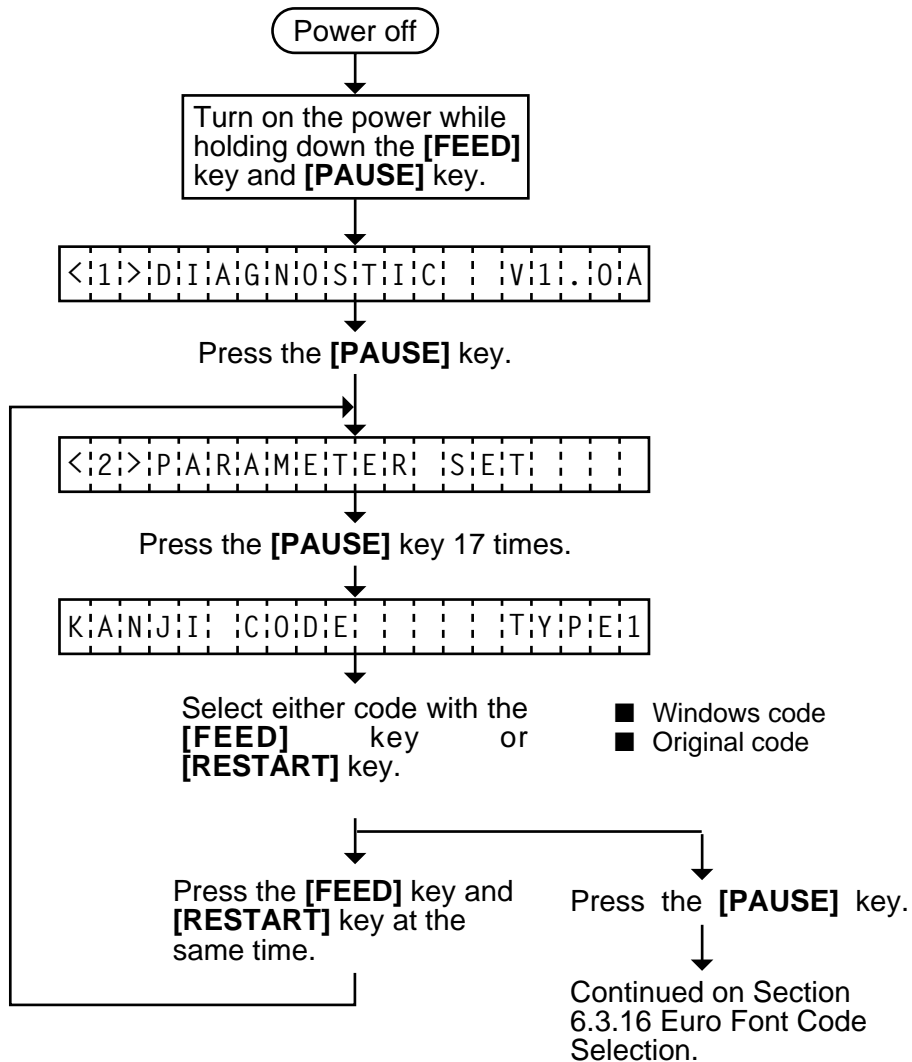

- NOTES:**
1. Holding the **[FEED]** key or **[RESTART]** key down for more than 0.5 seconds enables a fast forward.
  2. A changed Kanji code is stored in memory by pressing the **[PAUSE]** key.

6.3.16 Euro Font Code Selection

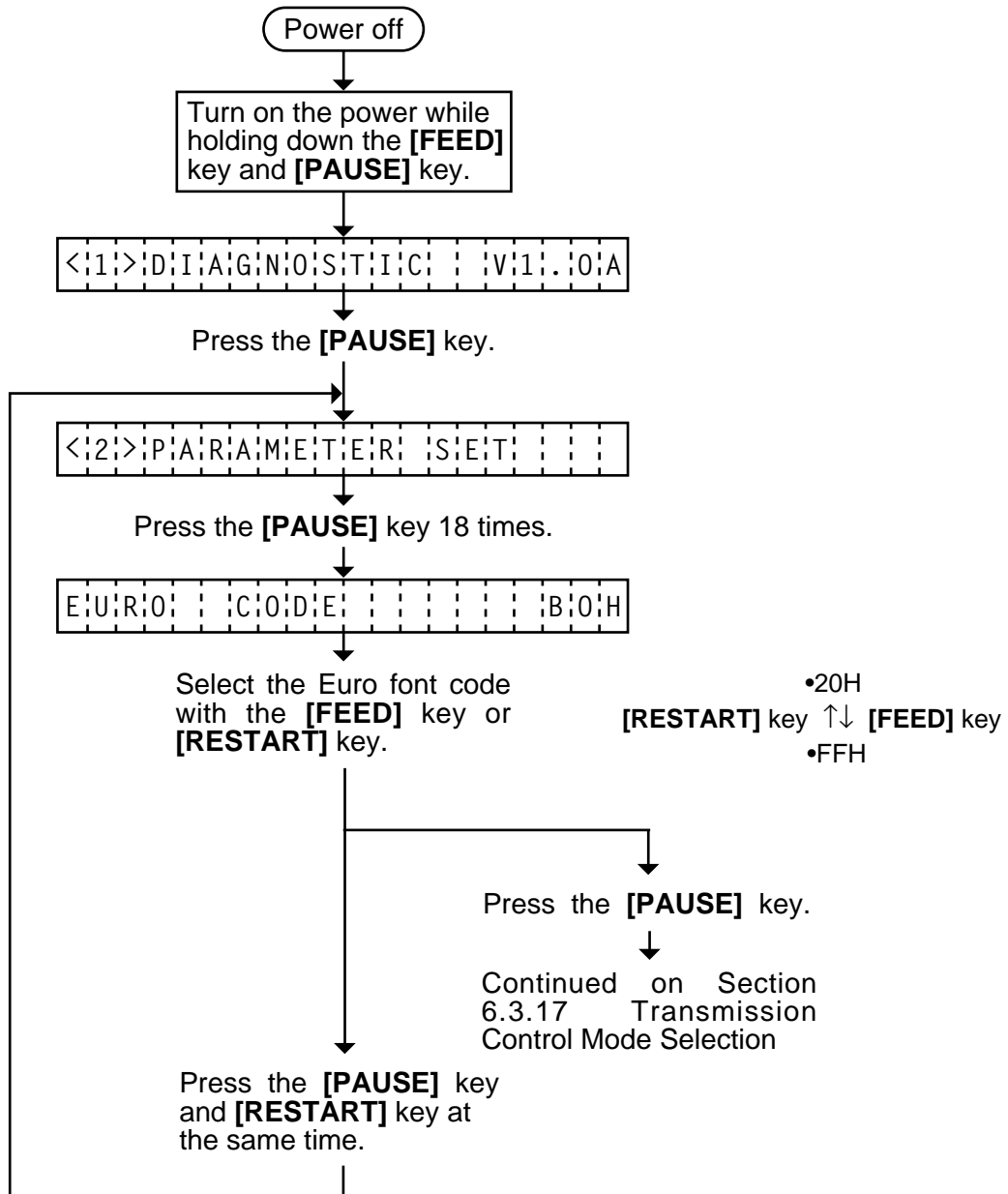

- NOTES:**
1. Holding the [FEED] key or [RESTART] key down for more than 0.5 seconds enables a fast forward.
  2. A changed Euro font code is stored in memory by pressing the [PAUSE] key.

6.3.17 Transmission Control Mode Selection

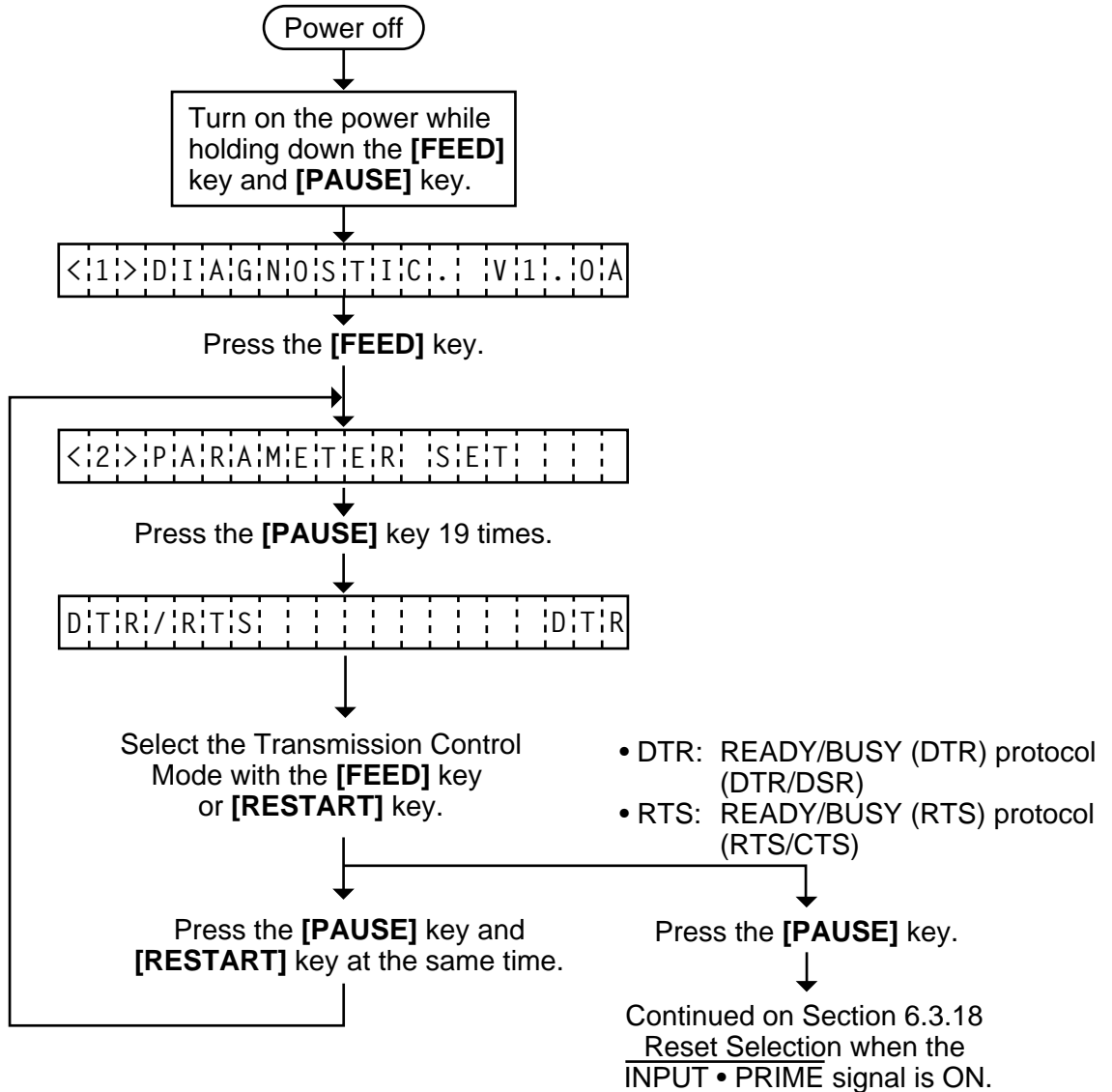

- NOTES:** 1. Holding the [FEED] key or [RESTART] key down for more than 0.5 seconds enable.  
 2. A changed Transmission Control Mode is memory by pressing the [PAUSE] key.

**6.3.18 Reset Selection when the INPUT • PRIME Signal is ON.**

Reset ON/OFF when the INPUT • PRIME signal ON is selected.

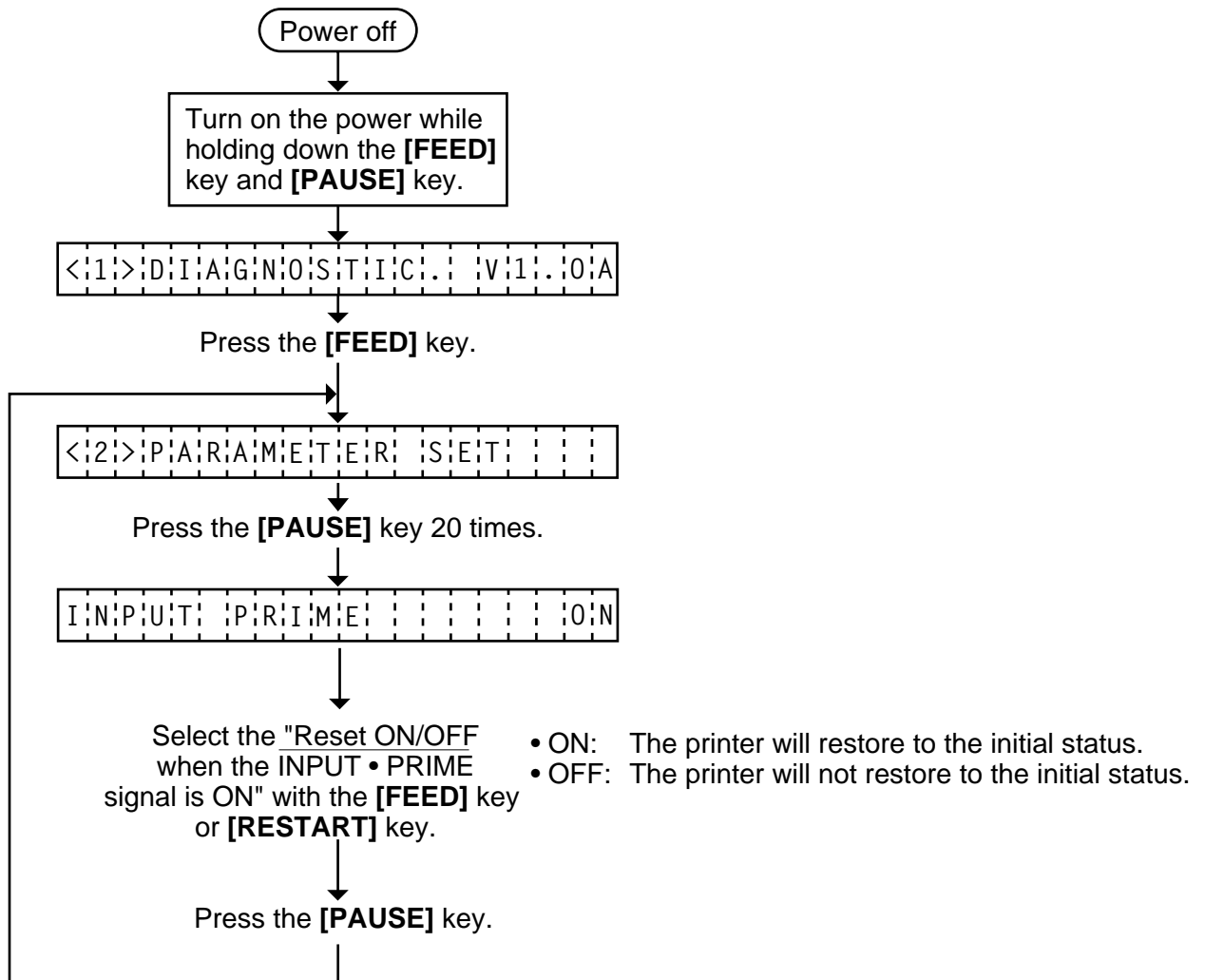

- NOTES:** 1. Holding the **[FEED]** key or **[RESTART]** key down for more than 0.5 seconds enable.
2. A changed "Reset ON/OFF when the INPUT • PRIME signal is ON" is stored in memory by pressing the **[PAUSE]** key.

## 6.4 TEST PRINT MODE

Test print mode contains normal test print and process test print.

### 6.4.1 Normal Test Print

Five kinds of test prints are provided in the test print mode. When performing the test print, 7 parameters should be set. The default parameter at power on is as below:

- ISSUE COUNT : 1
- PRINT SPEED : 5 inch/sec.
- SENSOR : Transmissive sensor
- RIBBON : Transmissive ribbon
- TYPE : Batch (without cut)
- LABEL LENGTH : 76 mm
- PAPER FEED : Feed

Operating procedure for the test mode is provided below.

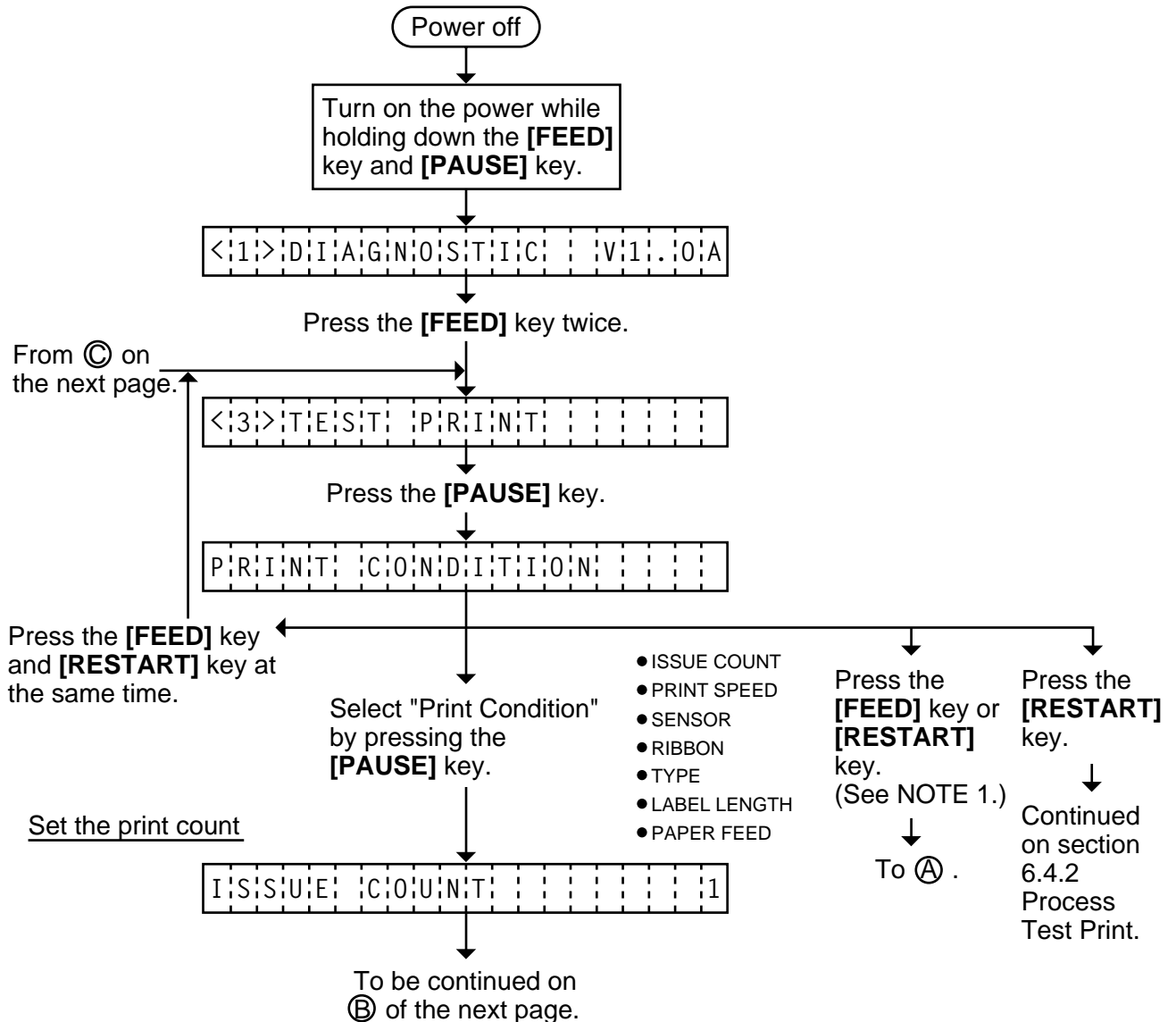

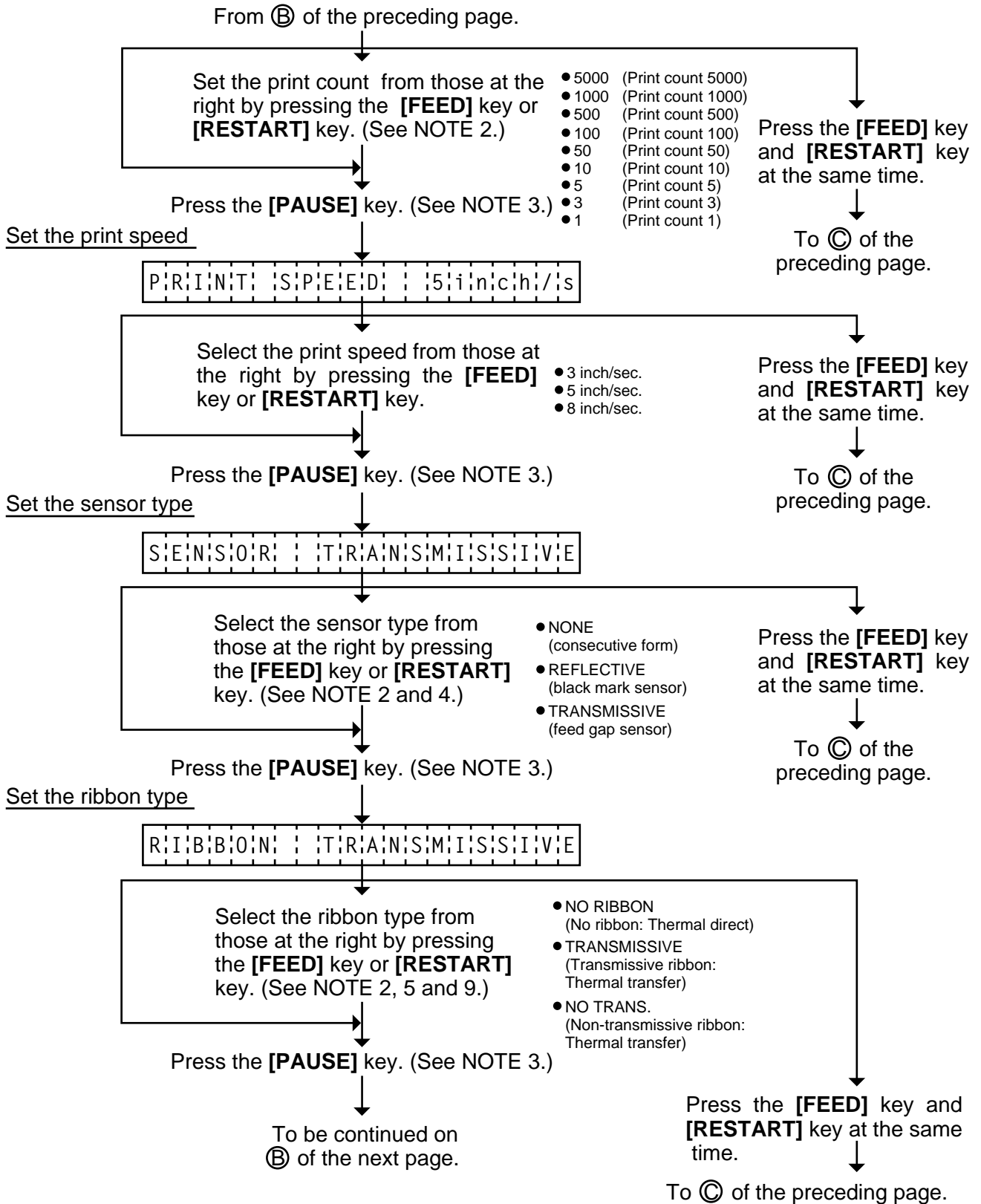



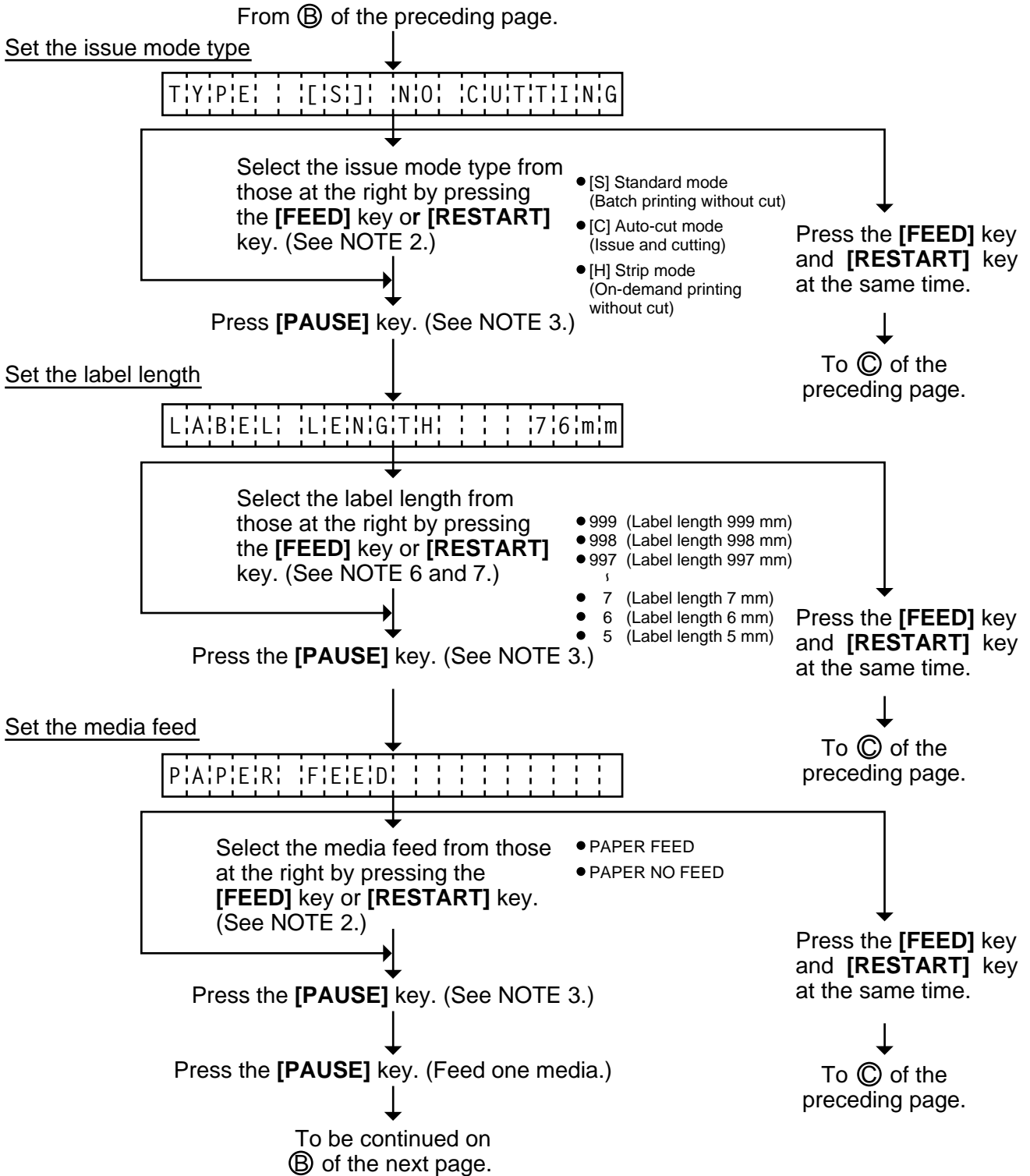

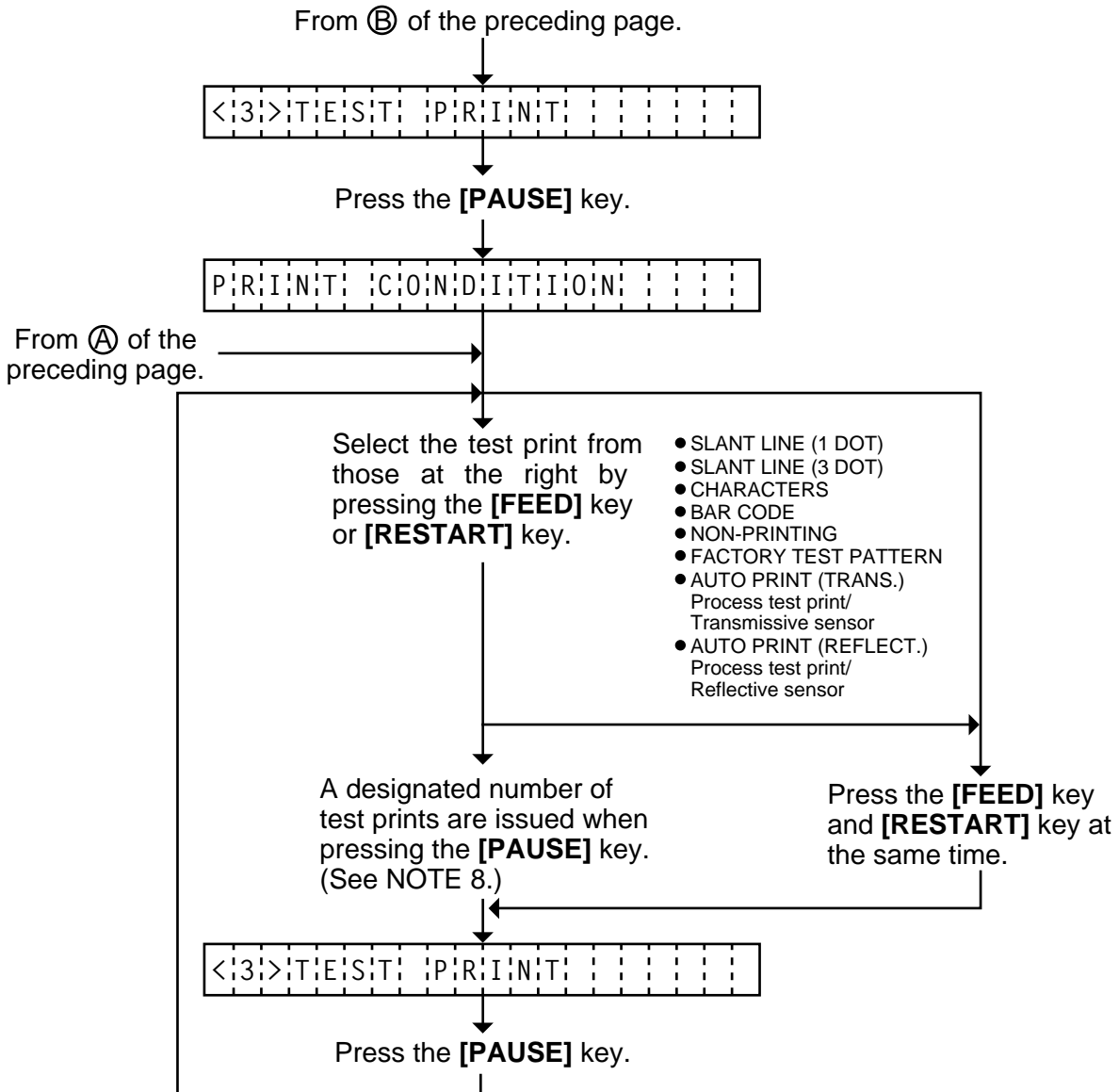

- NOTES:**
1. When there is no change to the print condition, select one of the test print options to issue the test print.
  2. Holding the **[FEED]** key or **[RESTART]** key down for more than 0.5 seconds enables a fast forward.
  3. A selected print condition is activated when the **[PAUSE]** key is pressed.
  4. When the feed gap sensor is selected, the gap between labels becomes 3mm long.
  5. Non-transmissive (NON TRANS.) ribbon cannot be used so the ribbon type must be set to transmissive (TRANS.) ribbon or no ribbon.
  6. A label size greater than the image buffer length cannot be designated. The image buffer length differs according to memory size. If designated, the printer prints in the image buffer, or the printer stops because of an error.
  7. Pressing the **[FEED]** key changes the label length -1 mm, pressing the **[RESTART]** key changes +1 mm.
  8. When an error occurs during a test print, the error message is displayed and printing is stopped. The error is cleared by pressing the **[PAUSE]** key and the display shows "<3> TEST PRINT". Printing is not automatically resumed after the error is cleared.

9. When the transmissive ribbon is selected and DIP SW. 1-1 is set to ON, and the space area is also 20 mm or more, the printer automatically enters ribbon saving print mode.
10. When "AUTO PRINT" is selected, 5 pcs. of the 3-dot slant line labels, bar code labels and character labels are printed respectively after one label is fed.

■ Test Print Sample

• Slant line (1 dot)

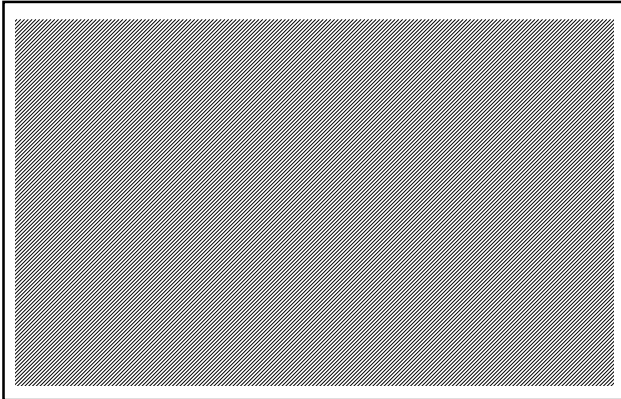

Fig. 6-21

• Slant line (3 dot)

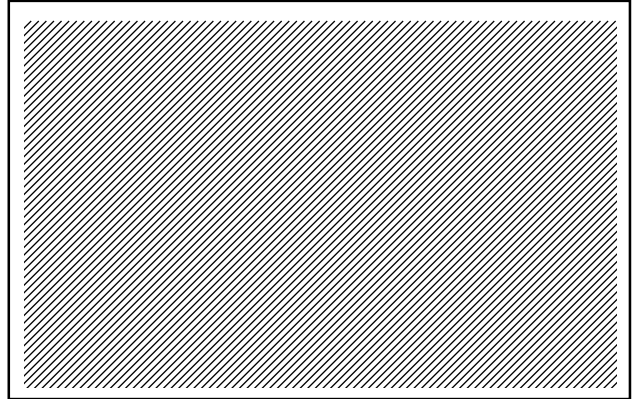

Fig. 6-22

• Characters

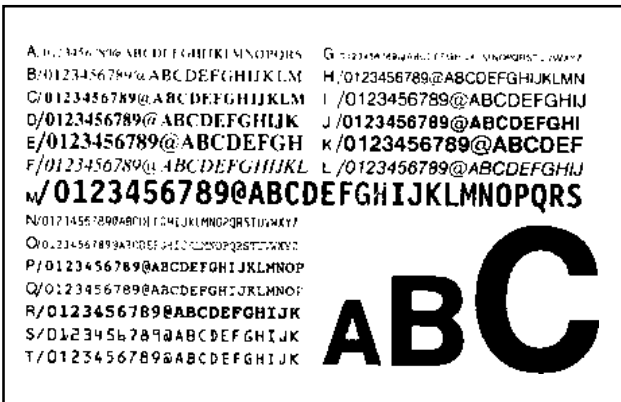

Fig. 6-23

• Bar code

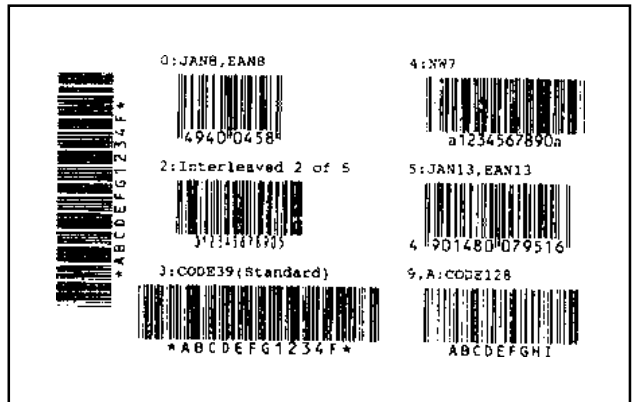

Fig. 6-24

• Factory Test Pattern

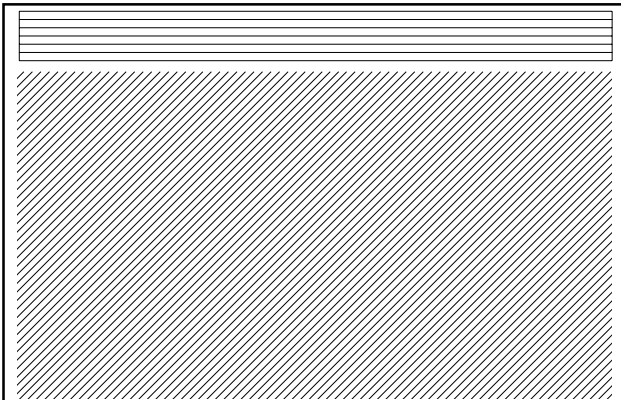

Fig. 6-25

6.4.2 Process Test Print

In the process test print, the test print is automatically performed on the following conditions. Parameter setting and print tone fine adjustment value is ignored.

- OPERATION : One label feed, 3-dot slant line print, bar code print, character print
- ISSUE COUNT : 5 labels each
- PRINT SPEED : 8 inches/sec.
- SENSOR : Transmissive sensor (feed gap sensor) or reflective sensor (black mark sensor)
- RIBBON : Transmissive ribbon
- TYPE : Batch (without cut)
- LABEL LENGTH: 76 mm
- PRINT TONE FINE ADJUSTMENT VALUE : + 0

Operating procedure for the test mode is provided below.

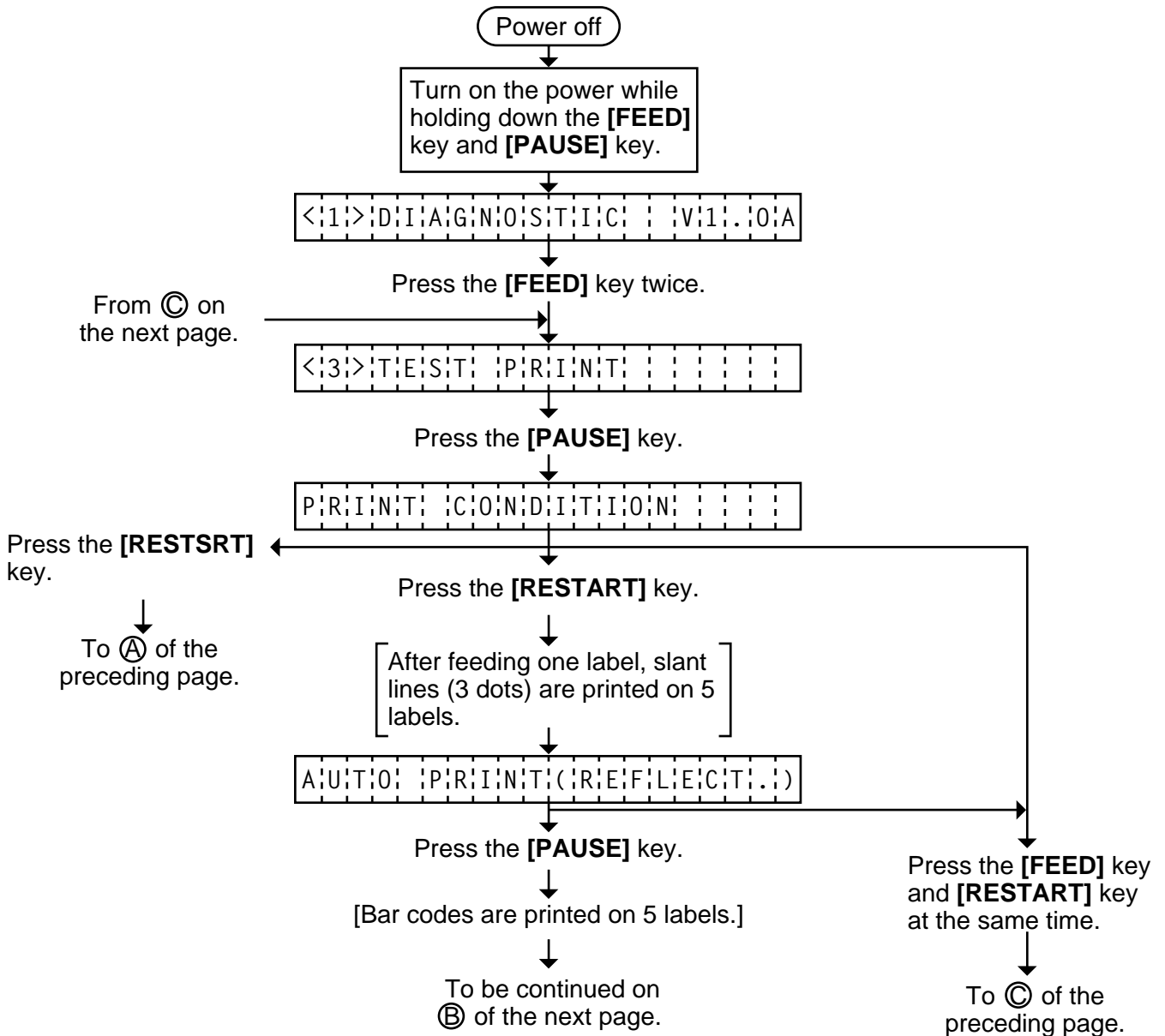

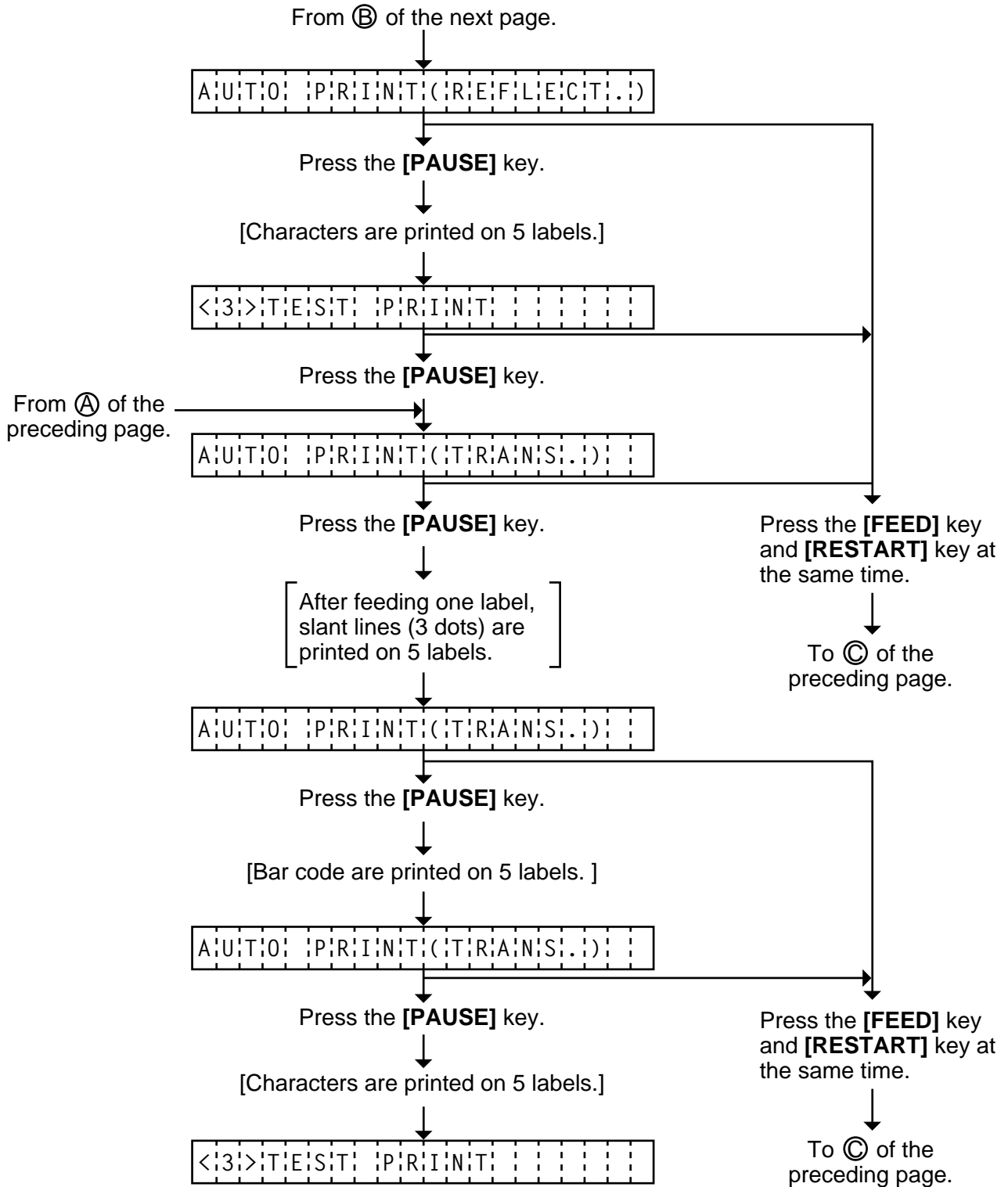

## 6.5 SENSOR SETTING MODE

Thermistor check and black mark/feed gap sensor settings are provided in the sensor setting mode. The value set in this mode is printed as data of sensor 2 in Automatic diagnosis printing in self test mode.

### 6.5.1 Thermistor Check

Thermistor check should be performed to check the environmental temperature and print head temperature after the excess head temp. error occurs or batch printing is performed for a long time.

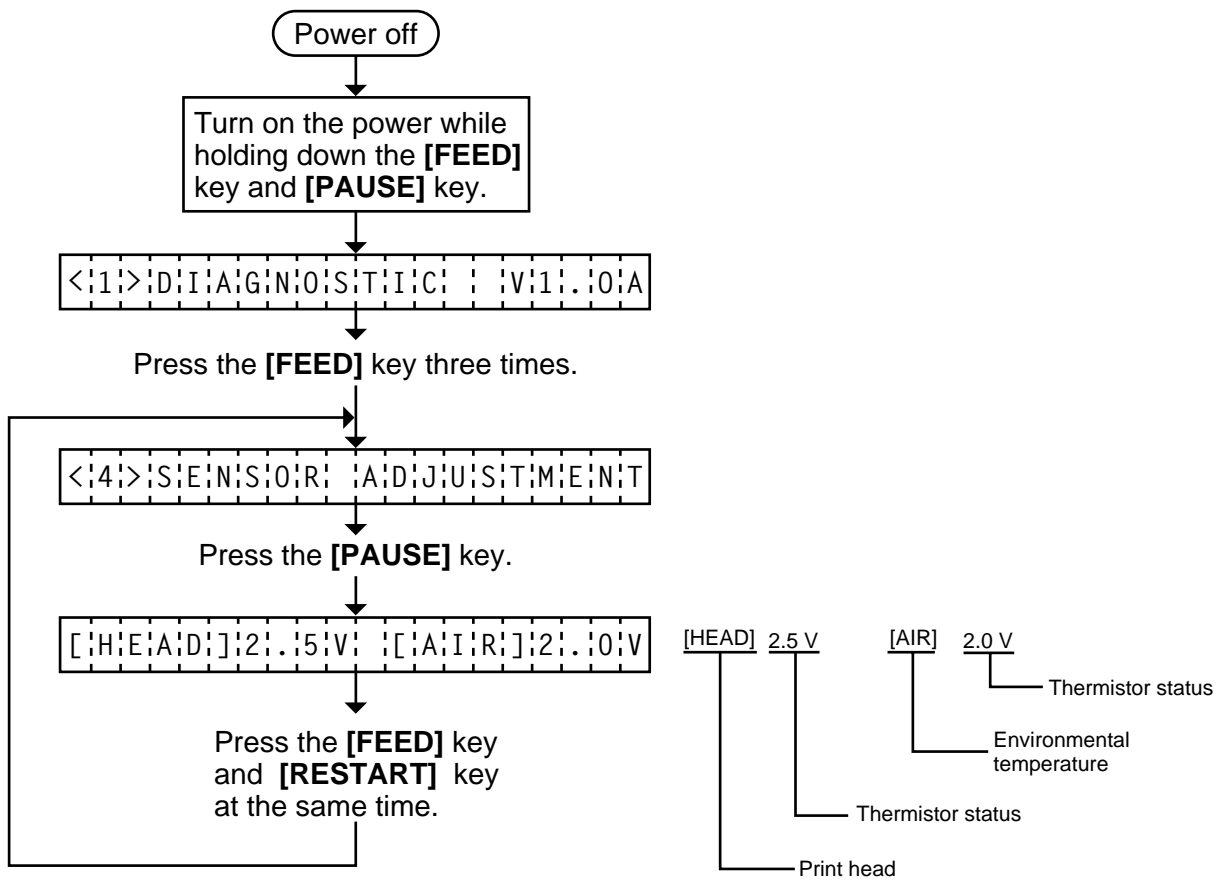

**NOTE:** Since the thermistor is supervised every 200 ms while displaying the status, the display could vary.

### 6.5.2 Black Mark Sensor Adjustment

Black mark sensor setting should be performed after replacing the CPU PC board or changing the tag paper to other maker's one, or when a paper feed error occurs.

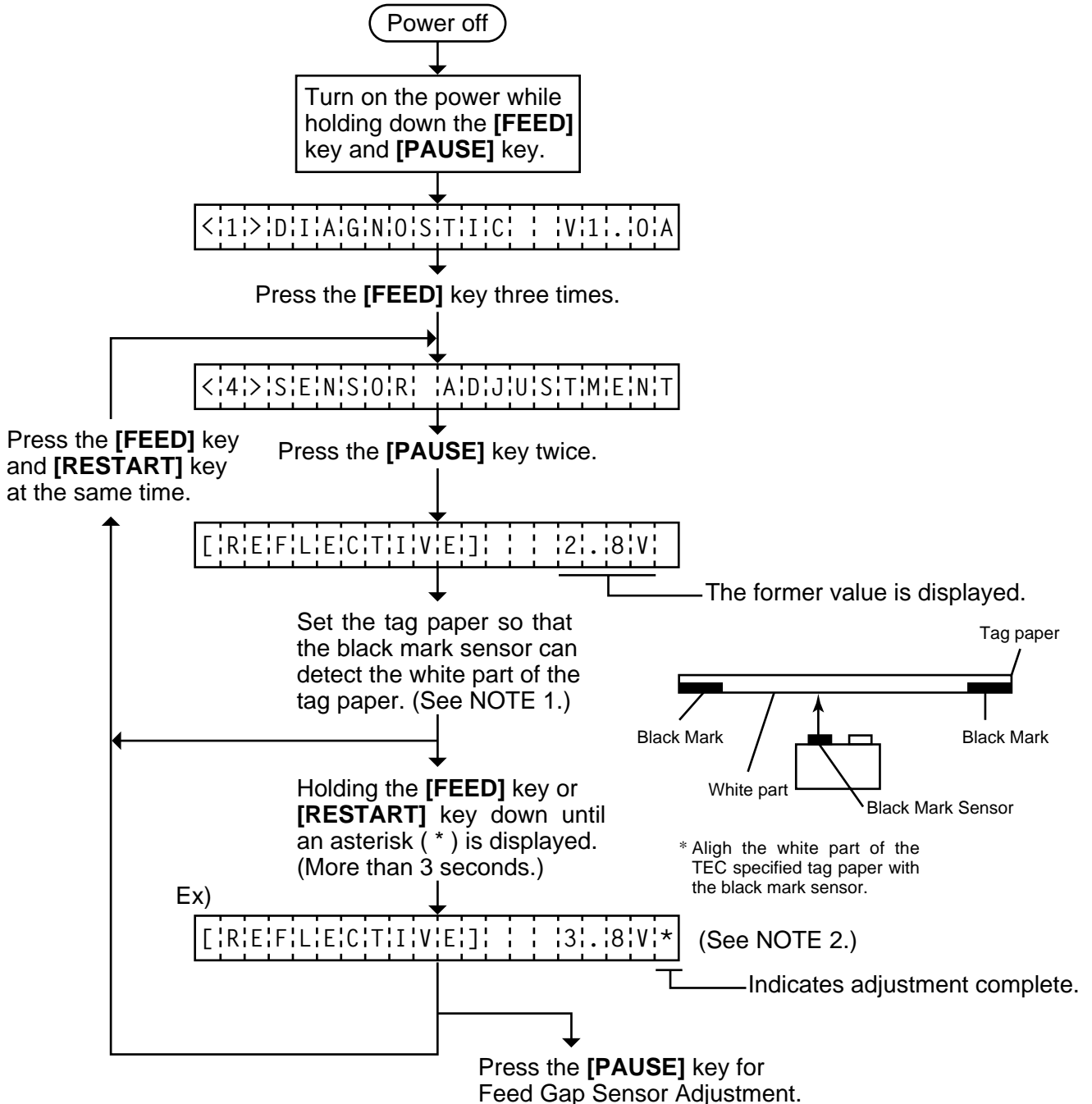

- NOTES:**
1. Make sure to adjust the black mark sensor using the white part of the tag paper as a criterion. Though an adjustment can be performed with the black mark, it may cause a paper jam error.
  2. Pressing the [PAUSE] key validates the sensor adjustment. The value of the sensor is displayed up to 5.0 V.

### 6.5.3 Feed Gap Sensor Adjustment

Feed gap sensor setting should be performed after replacing the CPU PC board or changing the label to other maker's one, or when a paper feed error occurs.

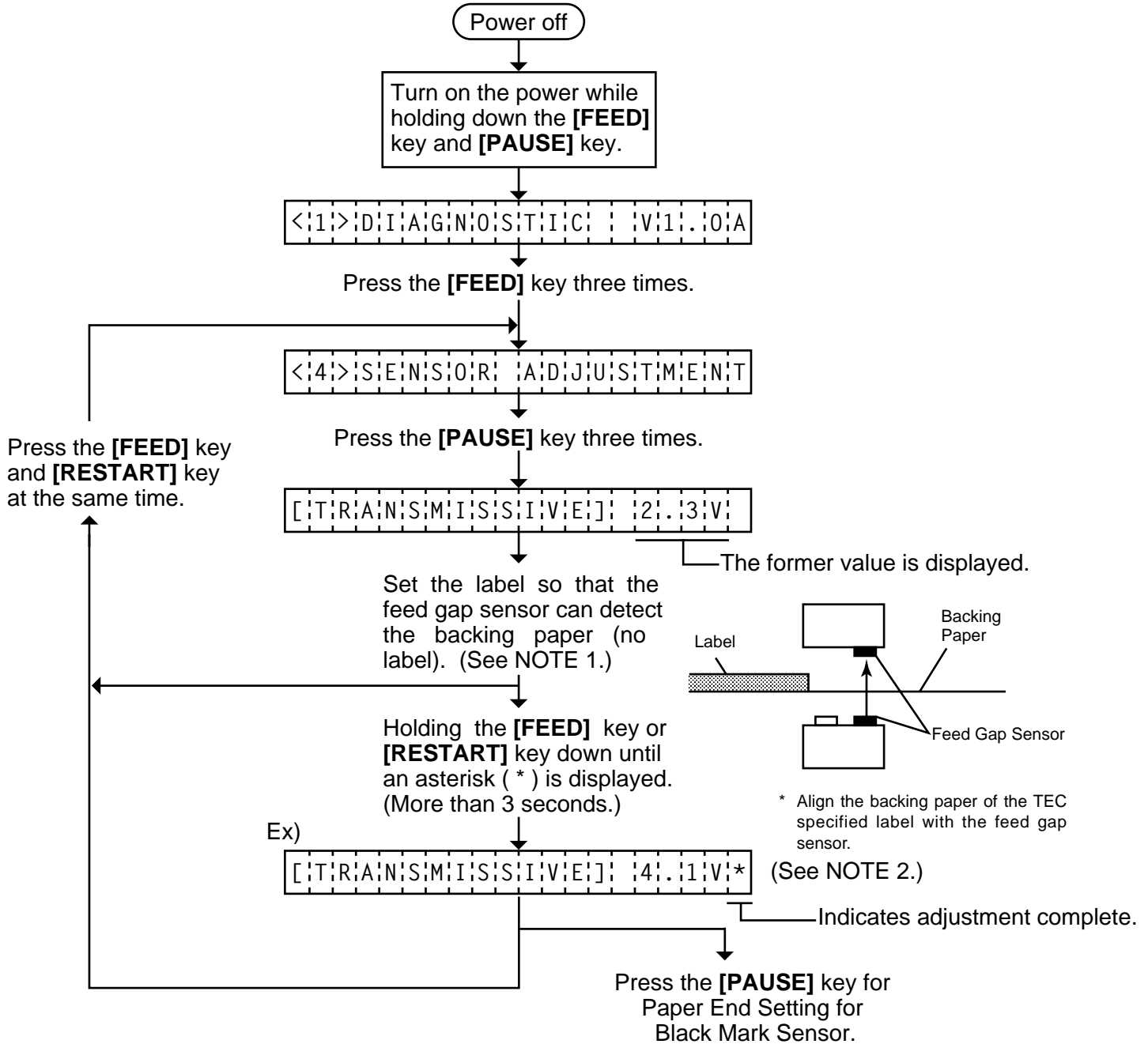

**NOTES:** 1. Make sure to adjust the feed gap sensor using the backing paper with no label as a criterion. Though an adjustment can be performed with the label, it could cause a paper jam error.

2. Pressing the [PAUSE] key validates the sensor adjustment. The value of the sensor is displayed up to 5.0 V.



### 6.5.4 Paper End Setting for Black Mark Sensor

Paper end setting should be performed after replacing the CPU PC board or changing the tag paper to other maker's one, or when a paper feed error occurs.

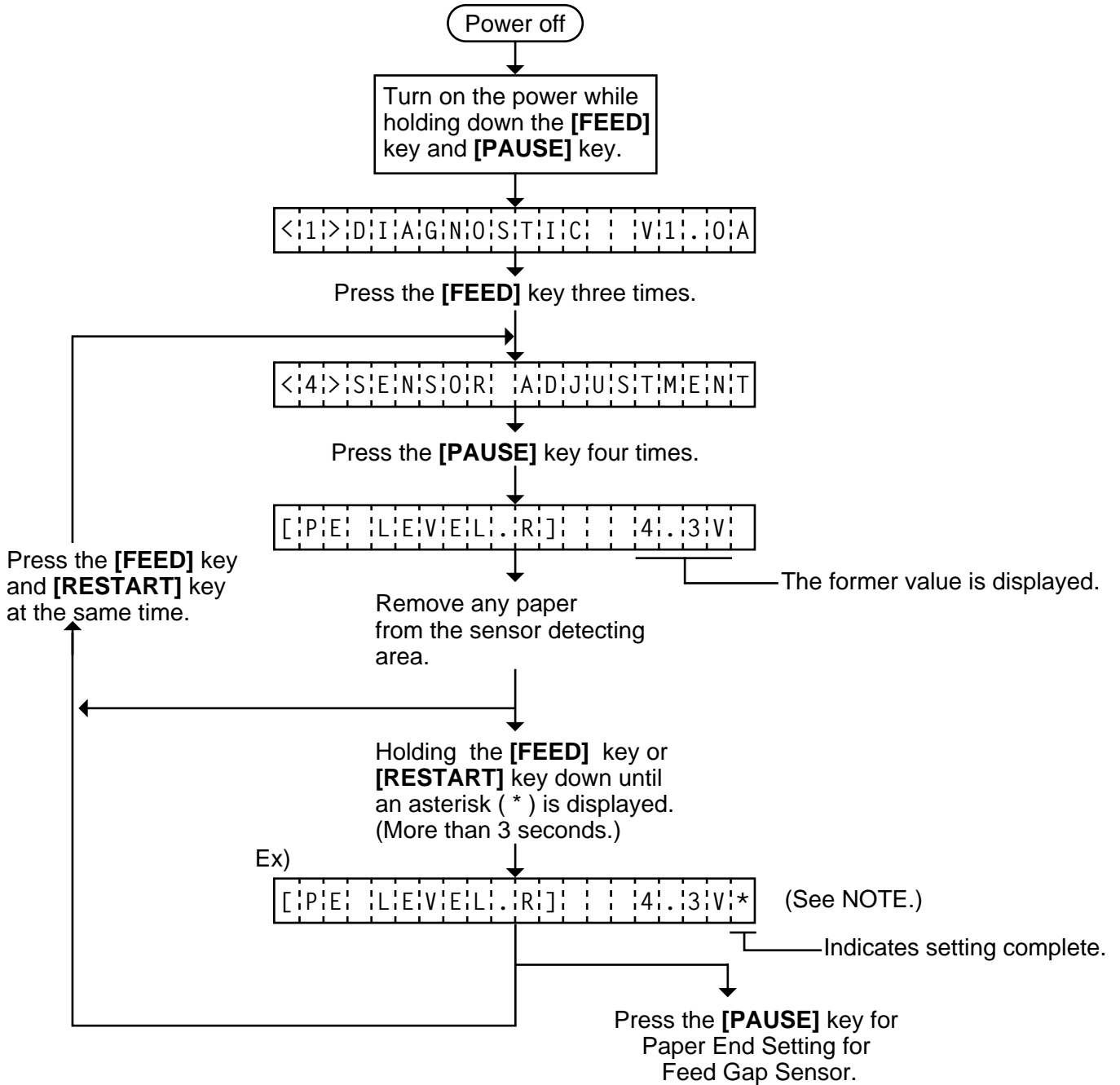

**NOTE:** Pressing the [PAUSE] key validates the sensor setting. The value of the sensor is displayed up to 5.0 V.

### 6.5.5 Paper End Setting for Feed Gap Sensor

Paper end setting should be performed after replacing the CPU PC board or changing the label to other maker's one, or when a paper feed error occurs.

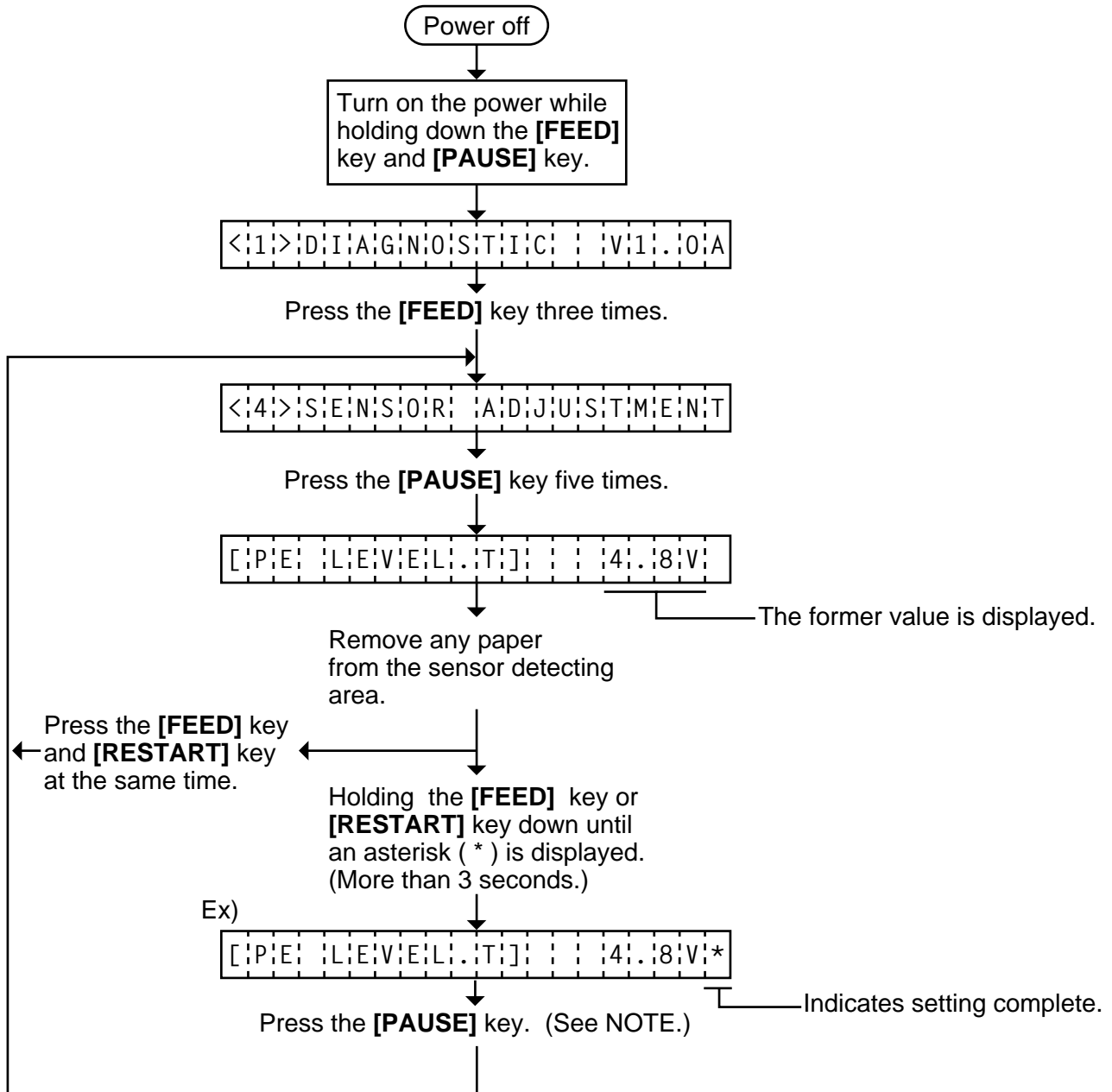

**NOTE:** Pressing the [PAUSE] key validates the sensor setting. The value of the sensor is displayed up to 5.0 V.

## 6.6 RAM CLEAR MODE

In RAM clear mode, various data written on the EEP-ROM can be initialized. There are two clear functions; Maintenance counter clear and parameter clear in the parameter setting mode. After referring to the following table specify and clear or initialize the data.

### ■ RAM Clear Mode Table

Mode Name	Function																				
NO RAM CLEAR	If you enter the RAM clear mode by mistake, specify this mode to escape from the RAM clear mode without executing RAM clear.																				
MAINTE. COUNTER CLEAR	<p>After replacing the print head, cutter module, ribbon feed/rewind motor, solenoid and CPU PC Board, clear the maintenance counter. The following data will be cleared to zero. Confirmation can be made through the maintenance counter procedure in self test mode. (See NOTE 1 and 2.)</p> <table border="1"> <thead> <tr> <th>Item</th> <th>Initial Value</th> </tr> </thead> <tbody> <tr> <td>Media distance covered</td> <td>0.0 Km</td> </tr> <tr> <td>Print distance</td> <td>0.0 Km</td> </tr> <tr> <td>Cut count</td> <td>0 times</td> </tr> <tr> <td>Head up and down count</td> <td>0 times</td> </tr> <tr> <td>Ribbon motor driving time</td> <td>0 hours</td> </tr> <tr> <td>Solenoid driving time</td> <td>0 hours</td> </tr> <tr> <td>RS-232C hardware error count</td> <td>0 times</td> </tr> <tr> <td>System error count</td> <td>0 times</td> </tr> <tr> <td>Momentary power failure count</td> <td>0 times</td> </tr> </tbody> </table>	Item	Initial Value	Media distance covered	0.0 Km	Print distance	0.0 Km	Cut count	0 times	Head up and down count	0 times	Ribbon motor driving time	0 hours	Solenoid driving time	0 hours	RS-232C hardware error count	0 times	System error count	0 times	Momentary power failure count	0 times
Item	Initial Value																				
Media distance covered	0.0 Km																				
Print distance	0.0 Km																				
Cut count	0 times																				
Head up and down count	0 times																				
Ribbon motor driving time	0 hours																				
Solenoid driving time	0 hours																				
RS-232C hardware error count	0 times																				
System error count	0 times																				
Momentary power failure count	0 times																				
PARAMETER CLEAR	<p>This clear should be employed when initializing the following parameters to the settings before shipment. Confirmation can be made through the automatic diagnostic procedure in self test mode. (See NOTE 1 and 2.)</p> <table border="1"> <thead> <tr> <th>Item</th> <th>Initial Value</th> </tr> </thead> <tbody> <tr> <td>Feed length fine adjustment (PC)</td> <td>0.0 mm</td> </tr> <tr> <td>Cut/strip position fine adjustment (PC)</td> <td>0.0 mm</td> </tr> <tr> <td>Back feed length fine adjustment (PC)</td> <td>0.0 mm</td> </tr> <tr> <td>Print tone fine adjustment (Thermal transfer) (PC)</td> <td>0 step</td> </tr> <tr> <td>Print tone fine adjustment (Thermal direct) (PC)</td> <td>0 step</td> </tr> <tr> <td>Feed length fine adjustment (KEY)</td> <td>0.0 mm</td> </tr> <tr> <td>Cut/strip position fine adjustment (KEY)</td> <td>0.0 mm</td> </tr> <tr> <td>Back feed length fine adjustment (KEY)</td> <td>0.0 mm</td> </tr> <tr> <td>Print tone fine adjustment (Thermal transfer) (KEY)</td> <td>0 step</td> </tr> </tbody> </table>	Item	Initial Value	Feed length fine adjustment (PC)	0.0 mm	Cut/strip position fine adjustment (PC)	0.0 mm	Back feed length fine adjustment (PC)	0.0 mm	Print tone fine adjustment (Thermal transfer) (PC)	0 step	Print tone fine adjustment (Thermal direct) (PC)	0 step	Feed length fine adjustment (KEY)	0.0 mm	Cut/strip position fine adjustment (KEY)	0.0 mm	Back feed length fine adjustment (KEY)	0.0 mm	Print tone fine adjustment (Thermal transfer) (KEY)	0 step
Item	Initial Value																				
Feed length fine adjustment (PC)	0.0 mm																				
Cut/strip position fine adjustment (PC)	0.0 mm																				
Back feed length fine adjustment (PC)	0.0 mm																				
Print tone fine adjustment (Thermal transfer) (PC)	0 step																				
Print tone fine adjustment (Thermal direct) (PC)	0 step																				
Feed length fine adjustment (KEY)	0.0 mm																				
Cut/strip position fine adjustment (KEY)	0.0 mm																				
Back feed length fine adjustment (KEY)	0.0 mm																				
Print tone fine adjustment (Thermal transfer) (KEY)	0 step																				

Mode Name	Function	
PARAMETER CLEAR	Item	Initial Value
	Print tone fine adjustment (Thermal direct) (KEY)	0 step
	X axis fine adjustment	0.0 mm
	Character code selection	PC-850
	Font zero selection	"0"(without slash)
	Control code selection	Auto.
	Ribbon type selection	Trans.
	Ribbon motor drive voltage fine adjustment (PC)	0
	Ribbon motor drive voltage fine adjustment (KEY)	0
	Strip wait status setting	1
	Stacker	OFF
	Status response	ON
	Threshold manual fine adjustment for the black mark sensor	1.0 V
	Threshold manual fine adjustment for the feed gap sensor	1.4 V
	Label pitch	76.2 mm
	Effective printing length	74.2 mm
	Effective printing width	80 mm
	With/Without ribbon	With
	Sensor type	Transmissive sensor (Feed gap sensor)
	Feed Speed	5 inch/sec.
	Issue mode	Standard (Batch printing)
	PC save automatic calling	ON
	Kanji code	TYPE 1
Euro font code	B0H	
Transmission Control Mode	DTR	
Reset selection when the INPUT•PRIME signal is ON.	ON	

- NOTES:**
1. Total media distance covered (TL FEED) and the adjustment value for the sensors cannot be cleared.
  2. Data stored on the flash memory card cannot be cleared with this procedure. To clear data on the flash memory card, send the format command to initialize the card. For details, refer to the External Equipment Interface Specification.
  3. For data to be cleared in the RAM clear mode, refer to the RAM clear mode table.
  4. After RAM clear is performed, the threshold setting value will turn to the default (0). When using pre-printed labels, be sure to set the threshold after referring to the Owner's Manual.

6.6.1 Maintenance Counter Clear

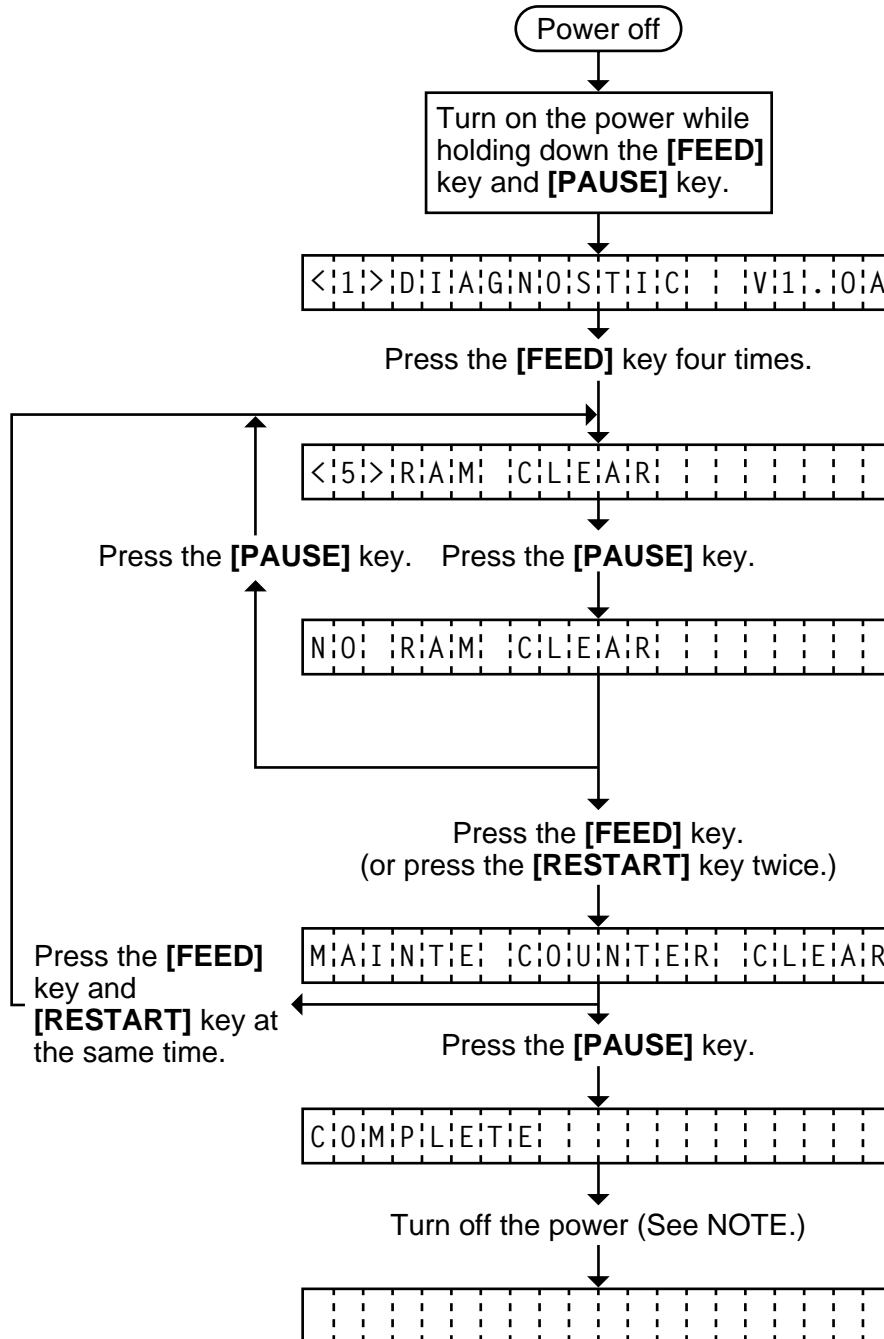

**NOTE:** Confirm that “COMPLETE” is displayed, then turn the power off.

6.6.2 Parameter Clear

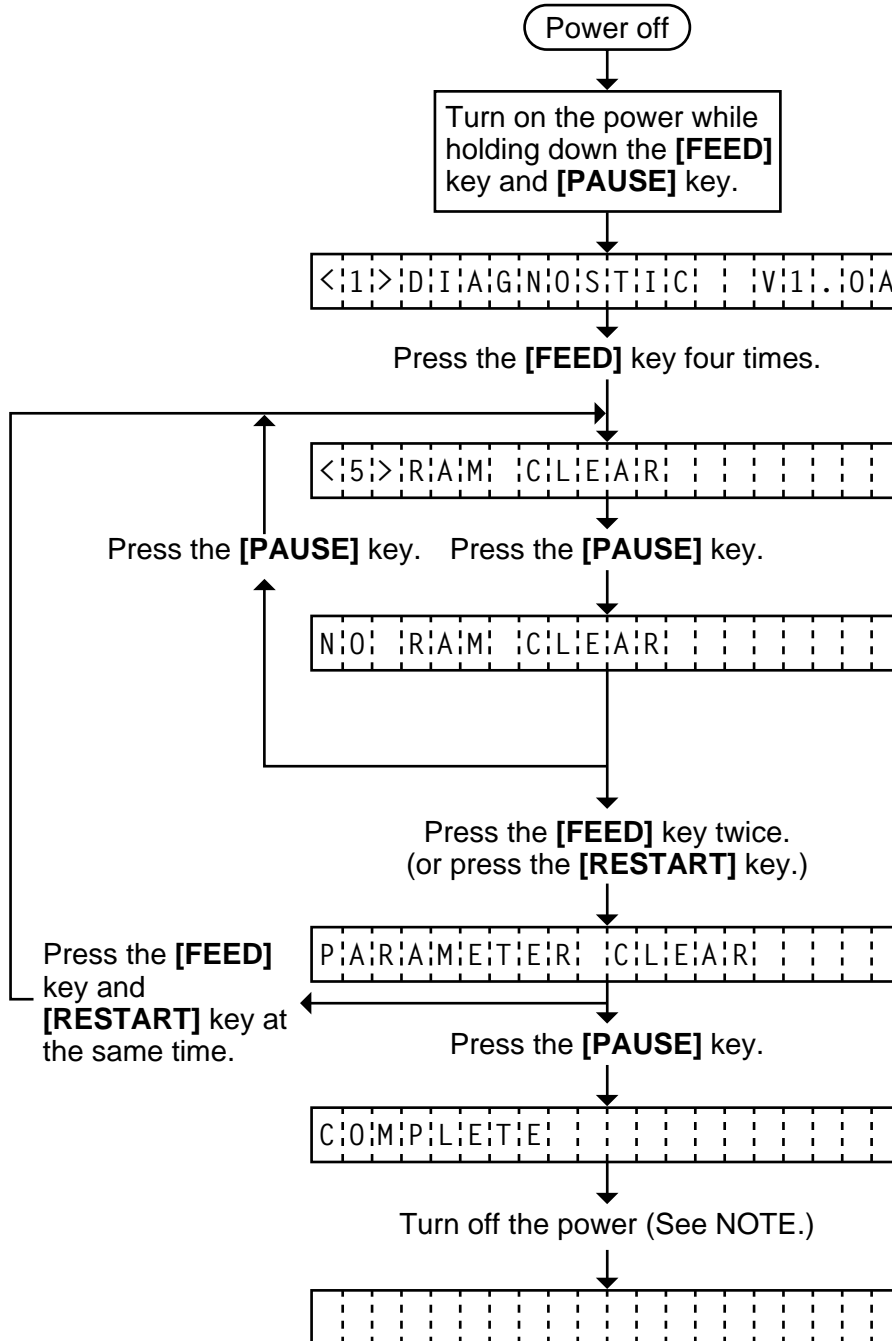

**NOTE:** Confirm that “COMPLETE” is displayed, then turn the power off.

## 7. PROGRAM DOWN LOAD

The main program for the printer has been written onto the flash ROM. If the main program is upgraded, due to the addition/change of the specification, download the main program from the PC to the printer with the down-load floppy disk and RS-232C interface or high speed PC interface.

### 7.1 FLOPPY DISK

- (1) Media ..... 3.5 inches (2DD)
- (2) System disk ..... 1 disk (This floppy disk contains the main program written onto the printer and the tool program for down load.)

### 7.2 SETUP

The transmission control code for the printer must be set to either the automatic selection or manual selection (ESC, NUL, LF). For details, refer to Section 6.3.8 Control Code Selection.

- (1) Program down load with RS-232C interface

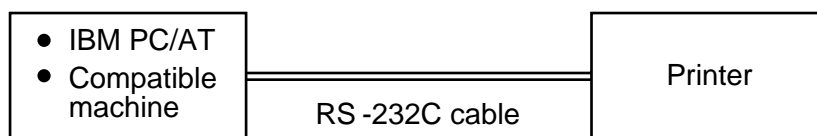

Connect the PC to the printer with an RS-232C cable. Set the DIP SW2 on the CPU PC board of the printer as follows:

SW#	Status	Function	Description
1	OFF	9600 BPS	Transmission Speed
2	ON		
3	OFF	1 bit	Stop bit length
4	ON	8 bits	Data length
5	OFF	No	Presence/absence of parity

- (2) Program down load with high speed PC interface

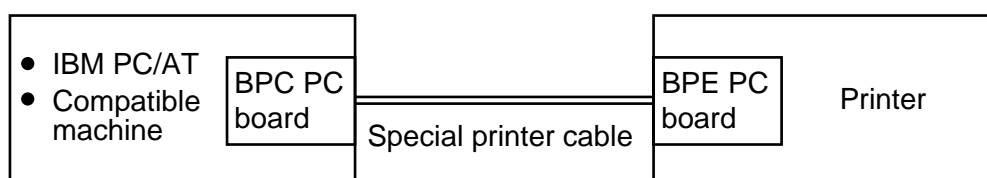

Install the BPC and BPE PC boards in the PC and printers, respectively, and connect both boards to each other with the special printer cable after referring to the Maintenance Manual Section 3.1. Refer to the Owner's Manual enclosed with the high speed PC interface board kit to set the DIP SW on the BPC PC board and to install the BPC driver in the PC (hard disk drive).

---

### 7.3 DOWN LOAD PROCEDURE

- (1) Turn the PC power on.
- (2) Turn the printer power on.
- (3) Inset the program down load floppy disk into the PC.
- (4) Change the drive to A. Type
- (5) Start the batch file "PDL". Type      
Or copy the contents of the floppy disk in to the hard disk and start the program in the hard disk.
- (6) After starting the batch file "PDL", the following menu is displayed. ㉑ indicates the main program version.

```
This is the down load program for B-X          DD-MM-YYYY

This program down line loads
the program file (Version V1.0A) to the B-X
               _____ ㉑
      Select the communication device. [ ]
      ( 1=RS-232C , 2=High Speed PC interface)

                Are you sure ? (Y/N) [ ]
      (Pressing the <Y key> will transmit the program file.)

-----
                To end the program press the <F1 key>

                                             ) ← ㉒
```

- (7) Select the interface.
  - RS-232C interface
  - High speed PC interface
- (8) Start the main program transmission.    
When changing the interface, press   and go back to step (7).
- (9) While the main program is being transmitted, the following message is displayed in line ㉑. "###"  
in the message, a running count, from 0 through 128 is shown indicating the number of KB transferred.  
\*\* Now transmitting (###/128KB)\*\*
- (10) When the transmission is successfully completed, the following message is displayed in line ㉑.  
End of Transmission. Continue (Y/N) ? [ ]
  - To continue
    - ① Turn the printer power off and exchange the printer with another one.
    - ② Turn the printer power on.
    - ③ Start the main program transmission.
  - To terminate



- (11) When an error occurs, the following message is displayed together with the error code in line ③.  
 The following error occurred during transmission. (ERROR=###)  
 Press any key to retry.

└── Error  
code

Doing so will revert to the displayed described in step (6). Refer to the error code to find the cause of the error. then retry the down load.

- (12) After terminating the down load, refer to the Maintenance Manual Section 6.2 SELF TEST MODE and perform diagnostic printing. Check that the printer operates properly and the main program version and checksum is printed on the label.

## 7.4 ERROR CODE

Error Code (#)	Error	Remarks
06	Communication error (Error is detected during command analysis.)	Status from the printer
07	Communication error (Parity error, overrun error or framing error occurred during communication with RS-232C.)	
50	Write error occurred during formatting of the flash ROM.	
51	Delete error occurred while data was being written onto the flash ROM.	
57	Chacksum error occurred in the transmission program data.	
81	Image data transmission request signal is not converted to "L"	Error detected in PC
82	Data FIFO of the high speed PC interface is not empty.	
88	Underfined status is received when a wating data in RS-232C.	
89	An IOCTL carry is detected in the high speed PC interface.	
90	A parameter error occurred.	
92	An overrun occurred in RS-232C.	
93	A parity error occurred in RS-232C.	
94	A framing error occrred in RS-232C.	
95	A break is detected in RS-232C.	
97	COM1 open error occurred in RS-232C.	
98	Undefined status is received against the loading setup command.	
99	Underfined status is received when the loading operation is terminated.	

Check the following when an error occurs:

- The printer power is turned on.
- The RS-232C cable or high speed PC interface cable is connected properly.
- The DIP SW on the CPU PC board or BPC PC board is set correctly.
- With the high speed PC interface, that the BPC/BPE PC boards are installed in the PC/printer properly.  
That the BPC driver is installed in the PC (hard disk drive) properly.